

GLT400

midi LOGGER

USER'S MANUAL

MANUAL NO. GLT400-UM-151

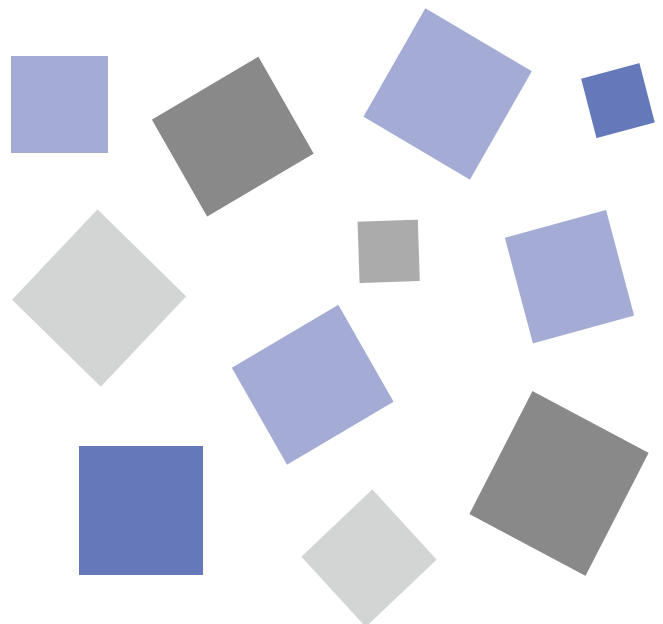





GRAPHTEC

To Ensure Safe and Correct Use









- To ensure safe and correct use of the GLT400, read this manual thoroughly before use.
- After having read this manual, keep it in a handy location for quick reference as needed.
- Do not permit small children to touch the GLT400.
- The following describes important points for safe operation. Please be sure to observe them strictly.

Conventions Used in This Manual

To promote safe and accurate use of the GLT400 as well as to prevent human injury and property damage, safety precautions provided in this manual are ranked into the five categories described below. Be sure you understand the difference between each of the categories.

 DANGER	This category provides information that, if ignored, is highly likely to cause fatal or serious injury to the operator.
 WARNING	This category provides information that, if ignored, is likely to cause fatal or serious injury to the operator.
 CAUTION	This category provides information that, if ignored, could cause physical damage to the GLT400.
 HIGH TEMPERATURE	This category provides information that, if ignored, is likely to cause burns or other injury to the operator due to contact with high temperature.
 ELECTRICAL SHOCK	This category provides information that, if ignored, is likely to expose the operator to electrical shock.

Description of Safety Symbols

	The  symbol indicates information that requires careful attention (including warnings). The specific point requiring attention is described by an illustration or text within or next to the  symbol.
	The  symbol indicates an action that is prohibited. Such prohibited action is described by an illustration or text within or next to the  symbol.
	The  symbol indicates an action that must be performed. Such imperative action is described by an illustration or text within or next to the  symbol.

Safety Precautions

⚠ WARNING

Be sure to securely connect the GLT400's GND terminal.

- After checking that the power switch is turned off, connect the power cord's female plug to the GLT400 and then connect its male plug into the electrical socket.
- For grounding, use a ground wire with a diameter of at least 0.75 mm². When using the GLT400 in an environment where grounding is not possible, ensure measured is no greater than 50 V (DC or rms).

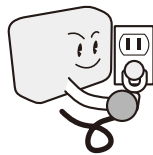

If the GLT400 generates smoke, is too hot, emits a strange odor, or otherwise functions abnormally, turn off its power and unplug its power cord from the electrical socket.

- Use of the GLT400 in such status may result in a fire hazard or electrical shock.
- After checking that smoke is no longer being generated, contact your sales representative or nearest Graphtec vendor to request repair.
- Never try to perform repair yourself. Repair work by inexperienced personnel is extremely dangerous.



Use prohibited

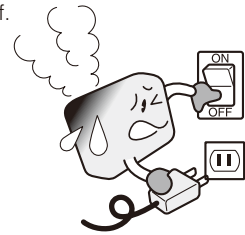

Before turning on the GLT400, ensure that the electric socket's supply voltage conforms to the GLT400's power rating.

- Use of a different supply voltage may cause damage to the GLT400 or a fire hazard due to electrical shock or current leakage.



Use prohibited

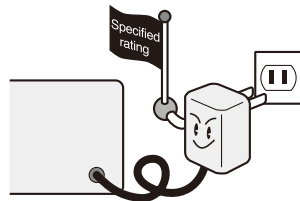

Never disassemble or remodel the GLT400.

- Such action may cause a fire hazard due to electric shock or current leakage.
- Contact with a high-voltage component inside the GLT400 may cause electric shock.
- If repair is required, contact your sales representative or nearest Graphtec vendor.



No disassembly



Avoid using the GLT400 in extremely dusty or humid places.

- Such use may cause a fire hazard due to electrical shock or current leakage.



Use prohibited



Watch out for electrical shock



Avoid using the GLT400 in places where it may be exposed to water such as bathrooms, locations exposed to wind and rain, and so on.

- An electrical shock or fire may be caused due to current leakage.



Avoid water



Watch out for electrical shock

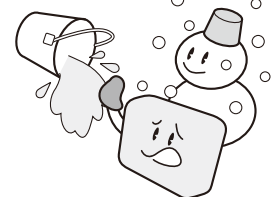

Prevent dust or metallic matter from adhering to the power supply connector.

- Adhesion of foreign matter may cause a fire hazard due to electrical shock or current leakage.



Use prohibited



Watch out for electrical shock

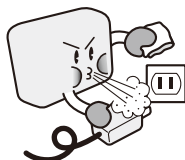

Never use a damaged power cord.

- Use of a damaged cord may result in a fire hazard due to electrical shock.
- If the cord becomes damaged, order a new one to replace it.



Unplug the power cord from the socket



Safety Precautions

! CAUTION

Do not use or store the GLT400 in a location exposed to direct sunlight or the direct draft of an air conditioner or heater.

- Such location may impair the GLT400's performance.



Use prohibited

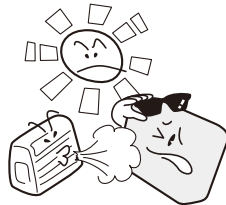

Do not place the receptacles containing fluid onto this device or close to this device.

- Fluid spilling inside the GLT400 may cause a fire hazard due to electrical shock or current leakage.



Avoid water



Watch out for electrical shock



Do not use the GLT400 in a location subject to excessive mechanical vibration or electrical noise.

- Such location may impair the GLT400's performance.



Use prohibited

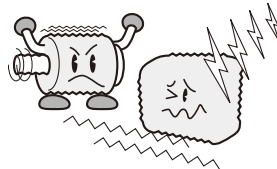

To insert or disconnect the power cord or a signal input cable, grasp the power cord's plug or the signal input cable's connector.

- Pulling the cord/cable itself damages the cord/cable, resulting in a fire hazard or electrical shock.



Use prohibited

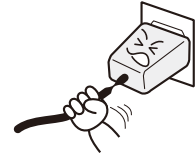

If fluid or foreign matters enters inside the GLT400, turn off the power switch and disconnect the power cord from the electrical socket.

- Use in such status may cause a fire hazard due to electrical shock or current leakage.
- Contact your sales representative or nearest Graphtec vendor to request repair.



Unplug the power cord from the socket

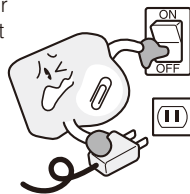

Do not use the AC power supply and the DC power supply other than the specified supply voltage for this device.

- Such action may cause a fire hazard due to electric shock or current leakage.



Use prohibited

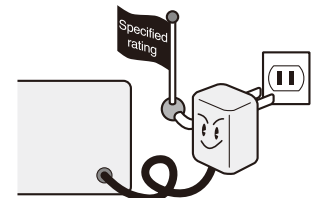

Do not attempt to lubricate the GLT400's mechanisms.

- Such action may cause the GLT400 to break down.



Use prohibited

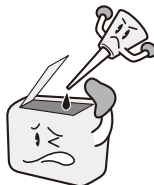

Never clean the GLT400 using a volatile solvent (such as thinner or benzene).

- Such action may impair the GLT400's performance.
- Clean off any soiled areas using a soft dry cloth.



Use prohibited

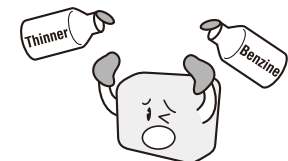

Be sure to use the Graphtec-supplied AC adapter.

- It will damage this device.



Use prohibited

Safety Precautions

CAUTION

Do not touch the input terminals after the signal cable is connected to the measuring objects that are containing the voltage.

- It will cause the electric shock.
- Ensure that the GLT400's power source is positioned so that it can easily be disconnected.



Strict observance



Watch out for electrical shock

Confirm the power of supplier of signal is turned off before connecting the input cables to the input terminal of this device to prevent the electric shock.

- It will cause the electric shock.



Strict observance



Watch out for electrical shock

Do not touch the device with wet hands.

- This can cause an electrical shock or malfunction.



Don't touch with wet hands

Be careful of static electricity.

- Static electricity may damage the device. To prevent this from happening, touch a different metal object to discharge any built-up static electricity before touching the GLT400.



CAUTION

Do not input the voltage that is exceeding the specification of this device.

- If a voltage exceeding the specified value is input, the semiconductor relay in the input section will be damaged. Never input a voltage exceeding the specified value even for a moment.



Strict observance

- Have an enough margin from the specification of withstanding voltage when using this device, it have to consider a noise and change of the measurement voltage.



CAUTION

- It will cause the fire or the electric shock when the voltage is input to the defective device.



Use prohibited

Do not block the air vent on the GLT400.

- This device will get damage when there is abnormal heat in this device.



Strict observance



HIGH TEMPERATURE

Confirm this device is not broken before the input cable is connected to the input terminal.

- It will cause the fire or the electric shock when the voltage is input to the defective device.



Use prohibited

Safety Precautions



When using the wireless unit (when option is installed), please note the following:

- If you have an implantable pacemaker or implantable defibrillator installed, radio signals from the device may have an effect on the operation of your implantable pacemaker or implantable defibrillator.



Strict observance

When using the wireless unit (when option is installed) in a medical establishment, please note the following rules:

- Please turn off the power of this product in hospital wards.
- Each medical institution has its own usage prohibitions in various areas. Be sure to follow these.



Strict observance

When using the wireless unit (when option is installed), please note the following:

- Turn off the device in places where wireless radio signal use is restricted, such as on aircrafts and in hospitals. The device can have an effect on electronic devices, medical devices, etc., and may cause malfunctions.



Use prohibited

When using the wireless unit (when option is installed), please note the following:

- In the event that the device has an effect on automatic electronic devices such as cars or elevators, immediately turn off the GLT400.



Use prohibited

Do not use the device in any way not specified in this manual. There is a danger that protective provisions will have not been put in place.



Use prohibited

This GLT400 is not meant for use with lifesaving devices or devices with mission-critical high reliability or high safety requirements (medical devices, aerospace devices, shipping devices, nuclear power devices, etc.). In the event that this GLT400 causes injury or property damage when used under these circumstances, the maker assumes absolutely no responsibility and is not liable.

Introduction

Thank you for purchasing the GLT400 midi LOGGER.

Please read this manual thoroughly before attempting to use your new product to ensure that you use it correctly and to its full potential.

Notes on Use

Be sure to read all of the following notes before attempting to use the GLT400 midi LOGGER.

1. Note on the CE Marking

The GLT400 midi LOGGER complies with the following standards.

- EN 61326-1 standard is based on the EMC Directive
- EN 61010-1 standard is based on the Low Voltage Directive (LVD)
- EN 301 489-17/-1, EN 300 328 standards are based on the Radio Equipment Directive (RED)
(Use optional B-568)

Although the GLT400 complies with the above-mentioned standards, be sure to use it correctly in accordance with the instructions and notes provided in this manual.

Moreover, use of the GLT400 by incorrect procedures may result in damage to the GLT400 or may invalidate its safeguards. Please confirm all of its notes regarding use and other related information to ensure correct use.

2. Warning

This is a Class A product according to the EMC directive. In a domestic environment, this product may cause radio interference or may be affected by radio interference to the extent that proper measurement cannot be performed.

3. Notes on Radio Law

When installing the wireless unit (option) on the GLT400, please note the following:

- Do not remove the technical standards compliance label. Do not use the device if it does not have a label on it.
- This GLT400 uses the 2.4GHz frequency band.

The following devices and transmitters use the same frequencies and should not be used near this GLT400:

- Microwave ovens
- Pacemakers and other industrial, science, and medical devices
- Radio transmitters used in mobile body identification devices on factory production lines, etc. (transmitters requiring licensing)
- Specified low-power radio transmitters (transmitters not requiring licensing)
Communications may become slower or impossible due to radio interference.

- The communications may become slower or impossible depending on the circumstances this GLT400 is used in. Take particular note of steel-reinforced, metal, concrete, and other structural materials that can inhibit radio waves.

■ This GLT400 is meant for use in Japan, the US, Europe, Taiwan, China and Korea. It has not been certified for use under any other country's radio laws.

The following are each region's certification marks.

Japan

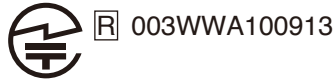

Taiwan



US

Contains FCC ID: ANSBP3591

China

CMIIT ID: 2015DJ5376

Europe

CE Mark

Korea

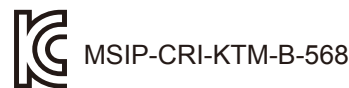

This device complies with part 15 of the FCC Rules. Operation is subject to the following two conditions:
(1) This device may not cause harmful interference, and (2) this device must accept any interference received, including interference that may cause undesired operation.

FCC CAUTION

Change or modifications not expressly approved by the party responsible for compliance could void the user's authority to operate the equipment.

This transmitter must not be co-located or operated in conjunction with any other antenna or transmitter.

4. Notes for Safe Operation

- (1) Be sure to use the Graphtec-supplied AC adapter. In environments where there is a lot of noise or where the power supply is unstable, we recommend that you ground the GLT400.
- (2) When a high-voltage signal cable has been connected to the main unit's analog signal input terminal, avoid touching the leads of the input terminal's signal cable to prevent electrical shock due to high voltage.
- (3) Ensure that the GLT400's power source is positioned so that it can easily be disconnected.
- (4) When connecting the high voltage signal line to the analog signal input terminal using the 4ch voltage/temperature terminal on the separately sold module (GS-4VT), avoid touching the leads of the input terminal's signal line to prevent electrical shock due to high voltage.
- (5) Do not input the voltage that is exceeding the specification of this device.
 - If a voltage exceeding the specified value is input, the semiconductor relay in the input section will be damaged. Never input a voltage exceeding the specified value even for a moment. It will cause the fire.
 - Have an enough margin from the specification of withstanding voltage when using this device, it have to consider a noise and change of the measurement voltage.
 - Confirm this device is not broken before the input cable is connected to the input terminal.
 - Please take care of the static electricity when the connecting the input cables or the thermocouples.
 - Do not touch the tip of thermocouples with bare hand after the thermocouples are connected to the terminal of this device when the tip of thermocouples is not insulated.
The static electricity of a human body will cause damage to this device.

- Do not put the tip of thermocouples to the object which is containing the static electricity when the tip of thermocouples is not insulated. The static electricity of object will cause damage to this device.
- Do not put the tip of thermocouples to the object which is containing the leaked high voltage of chassis or metal etc. when the tip of thermocouples is not insulated.
The leaked high voltage of object will cause damage to this device.
- We recommend that the insulation tape puts on the tip of thermocouples before connecting the thermocouples to the input terminals.
This will protect this device from the static electricity and the leaked high voltage.
* This applies to all the channels even if channel extension is used.

5. Notes on Functions and Performance

- (1) Be sure to connect the main unit to an AC or DC power supply that conforms to the rated range.
Connection to a non-rated power supply may cause the main unit to overheat and break down.
- (2) Do not block the vent on the main unit.
Continued operation with the vent blocked may cause the main unit to overheat and break down.
- (3) To avoid malfunctions and other damage, avoid using the GLT400 in the following locations.
 - Places exposed to high temperature and/or high humidity, such as in direct sunlight or near heating equipment.
Operating temperature range: -20 to 60°C (Supplied AC adapter: 0 to 45°C)
Operating humidity range: 5 to 85%R.H., non-condensing
 - Locations subject to excessive salt spray or heavy fumes from corrosive gas or solvents.
 - Excessively dusty locations.
 - Locations subject to strong vibrations or shock.
 - Locations subject to surge voltages and/or electromagnetic interference.
- (4) If the main unit becomes soiled, wipe it off using a soft, dry cloth. Use of organic solvents (such as thinner or benzene) causes deterioration and discoloration of the outer casing.
- (5) Do not use the GLT400 in the vicinity of other devices which are susceptible to electromagnetic interference.
- (6) Measured results may not conform to the stated specifications if the GLT400 is used in an environment which is subject to strong electromagnetic interference.
- (7) Insofar as possible, position the GLT400 input signal cables away from any other cables which are likely to be affected by electromagnetic interference.
- (8) For stabilized measurement, allow the GLT400 to warm up for at least 30 minutes after turning it on.

Notes on the Use of This Manual

- (1) All rights reserved. No part of this publication may be reproduced, stored in a retrieval system, or transmitted, in any form or by any means, without the prior written permission of Graphtec Corporation.
- (2) The specifications and other information in this manual are subject to change without notice.
- (3) While every effort has been made to supply complete and accurate information about this product, please address any inquiries about unclear information, possible errors, or other comments to your sales representative or nearest Graphtec vendor.
- (4) Notwithstanding the preceding paragraph, Graphtec Corporation assumes no liability for damages resulting from the use of the information contained herein or of the product.

Registered Trademarks

Microsoft and Windows are registered trademarks or trademarks of Microsoft Corporation in the U.S. and elsewhere.

Other company names and product names included in this manual are registered trademarks or trademarks of their respective companies.

Copyright

All copyrights regarding this manual belong to Graphtec Corporation.

CONTENTS

To Ensure Safe and Correct Use	i
Safety Precautions	ii
Introduction	I
Notes on Use	I
Notes on the Use of This Manual	IV
Registered Trademarks	IV
Copyright	IV

CHAPTER 1 General Description

1.1 Overview	1-2
1.2 Features	1-2
1.3 Operating Environment	1-3
Ambient Operating Conditions	1-3
Warming-up Before Use	1-3
Configuration When in Use	1-4
1.4 Notes on Temperature Measurement	1-5

CHAPTER 2 Checks and Preparation

2.1 Checking the Outer Casing	2-2
2.2 Checking the Accessories	2-2
Standard Accessories	2-2
2.3 Nomenclature and Functions	2-3
2.4 How to Install Expansion Terminal Base (option)	2-4
2.5 How to Remove Expansion Terminal Base	2-7
2.6 How to Connect Expansion Terminal Connection Cable (option)	2-9
2.7 How to Install Multiple Expansion Terminal Bases (option)	2-11
2.8 Connecting the Power Cable and Turning on the Power	2-18
2.9 Power Connection with USB PD	2-20
2.10 Connecting the Signal Input Cables	2-21
2.11 Logic Alarm Cable Connection and Functions	2-24
2.12 Mounting the SD CARD	2-27
2.13 Installing the Wireless Unit (B-568: option)	2-29
2.14 Connecting to a PC	2-31
2.15 Connecting the Humidity Sensor (option)	2-34
2.16 Precautions to Observe When Performing Measurement	2-35
2.17 Noise Countermeasures	2-38
2.18 When Fixing the GLT400 Body	2-39

CHAPTER 3 Operation and Function

3.1	Mode Switch Operation	3-2
3.2	Key Operation	3-4
3.3	Operation of LED	3-6
3.4	Buzzer	3-8
3.5	Description of Operation Mode	3-10
3.6	WEB Server Function	3-22
3.7	Other Functions	3-29

CHAPTER 4 Settings and Measurement

4.1	Overview of GLT400 SETTING APP	4-2
4.2	Description of Screen	4-5
4.3	Settings screen	4-9
	(1) Common settings	4-9
	(2) Amplifier settings	4-10
	(3) DATA settings	4-20
	(4) TRIG settings	4-27
	(5) Interface settings	4-33
	(6) OTHER settings	4-44
4.4	File Operations Screen	4-48
4.5	Monitor Screen	4-49
4.6	Save / Load Current Settings Screen	4-50

CHAPTER 5 Specifications

5.1	Standard Specifications	5-2
	Standard specifications (GLT400)	5-2
	Power supply function (USB Power Delivery)	5-3
	Memory devices	5-3
	PC I/F	5-3
	Standard terminal B-564/Screwless terminal B-564SL	5-4
	Withstand high-voltage high-precision terminal B-565	5-6
5.2	Function Specifications	5-8
	Function Specifications	5-8
	Trigger / Alarm Functions	5-8
	External Input/Output Functions	5-9
5.3	List of Error Codes	5-10
5.4	Accessories / Optional Accessories	5-12
	Control Software GL-Connection (in STAND-ALONE mode only)	5-12
	Accessories	5-12
	Wireless LAN Unit B-568 (Option)	5-12
	Humidity Sensor B-530 (Option)	5-13
	List of Options	5-13
5.5	External Dimensions	5-14
	GLT400 (with terminal)	5-14

INDEX	I-1
-------	-----

CHAPTER 1 General Description

This chapter provides a general description of the GLT400 and its features.

PRODUCT SUMMARY

1.1 Overview

1.2 Features

1.3 Operating Environment

1.4 Notes on Temperature Measurement

1.1 Overview

GLT400 is a compact, lightweight, multi-CH, and multi-purpose data logger.

There are three types of terminal units with 20 channels. By using the expansion terminal base, it is possible to measure up to 200 channels.

The GLT400 can save the high-capacity measurement data directly in the internal memory or SD CARD.

For the PC interface, as USB and Ethernet is included as standard, system configuration according to use is possible. As the Ethernet function is equipped with both WEB server and FTP server functions, remote supervision and data transfer are also possible. In addition, when the wireless LAN are combined by installing the wireless unit (option), the multipurpose remote measurement is also possible.

1.2 Features

Input

Adoption of a pluggable M3 screw type or screwless type input terminal facilitates wiring.

Up to 200 channels can be connected using the expansion terminal base and the terminal unit with 20 channels.

Because that the terminals of all terminal units have a whole CH isolated, the different standard signals can be measured at the same time.

In addition, when using the withstand high-voltage high-precision terminal, you can measure in the environmental conditions of high withstand voltage.

Operation

Easy operation has been achieved by eliminating the display unit and minimizing the operation unit.

Data Capture

The high-capacity measurement data can be saved directly in the internal memory or SD CARD.

Because the SD CARD is used as an external memory, you can measure a long period of time with peace of mind while data backup.

Because disk image can be used for the internal memory, multiple data can be saved.

The new ring memory capture function maintains latest data even after capturing for a long term. (You need to set how long you want to keep data.)

For voltage, temperature and humidity measurements, data can be captured at sampling rates of up to 10 msec per channel by using fewer measuring channels. (Temperature measurement can be done at sampling rates of 100 msec and higher.)

The GLT400 is equipped with the relay recording function, and 2GByte or more data can be saved by switching the to the other file without data missing. (When the capacity of one file reaches 2GByte, the file is switched.)

Data Control & Processing

The application software provided lets you set conditions and monitor data on a PC.

The USB drive mode function enables the internal memory and SD CARD to be recognized as an external drive by the PC.

(Set the Mode switch to USB DRIVE and then turn on the power of the GLT400.)

The WEB server function enables control and monitoring from a remote location without using dedicated software

The FTP client function enables backup of measurement data to the FTP server.

The NTP client function enables synchronization of the time with the NTP server.

Data can be captured remotely by installing the wireless unit (option).

1.3 Operating Environment

This section explains the operating environment for the GLT400.

Ambient Operating Conditions

- (1) Ambient temperature and humidity (the GLT400 must be operated within the following ranges.)
 - Temperature range: -20 to 60°C (Supplied AC adapter: 0 to 45°C)
 - Humidity range: 5 to 85%R.H.
 - * When the screwless terminal (B-564SL) is connected to the GLT400, it is necessary to use it in the environment of the GLT400.
- (2) Environment (do not use in the following locations.)
 - Outdoor
 - A Location such as being exposed to direct sunlight
 - Locations exposed to salty air, corrosive gases, or organic solvents
 - Dusty locations
 - Locations subject to vibration or impact
 - Locations subject to voltage surge or electromagnetic interference such as lightning or electric furnaces
- (3) Installation category (over-voltage category)
 - The GLT400 belongs to Installation Category II defined in IEC60664-1.
 - Never use the GLT400 for Installation Category III or IV.
- (4) Measurement category
 - The standard terminal (B-564) and screwless terminal (B-564SL) connected to the GLT400 should be not used in Measurement Category II, III, and IV.
 - The withstand high-voltage high-precision terminal (B-565) belongs to Category II. However, it should be not use in Category III or IV.
- (5) Altitude
 - Altitude up to 2000 m.
- (6) Mains supply voltage
 - 100 to 240 VAC \pm 10%
- (7) Pollution degree
 - POLLUTION DEGREE 2 in accordance with IEC60664.



If condensation occurs...

Condensation occurs in the form of water droplets on the device surfaces and interior when the GLT400 is moved from a cold to a warm location. Using the GLT400 with condensation will cause malfunctioning. Wait until the condensation has disappeared before turning on the power.

Warming-up Before Use

The GLT400 should be allowed to warm up with the power turned on for approximately 30 minutes to ensure that it operates according to the specified performance.

Configuration When in Use

Do not use the GLT400 standing upright or at an angle. It must always be laid flat or inclined on the stands.

<Usage Configuration>

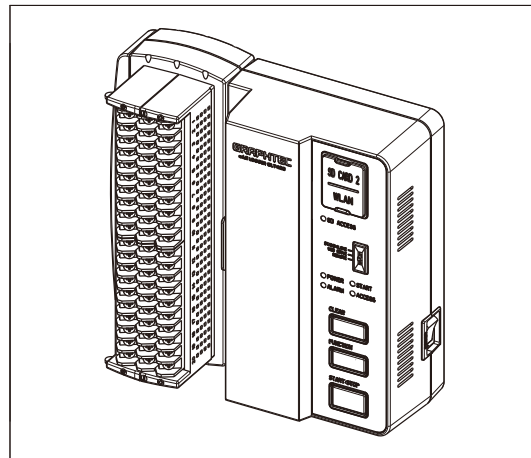
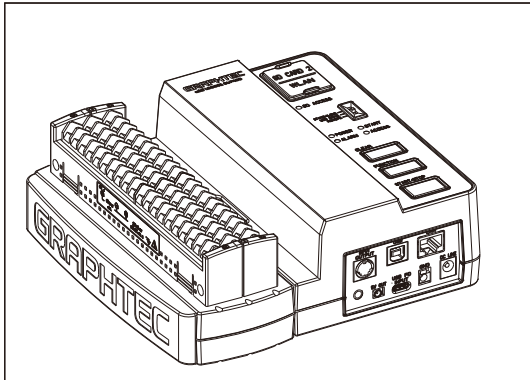

* To install vertically, use the DIN rail jig for GL840 expansion terminal (B-540: option).

CAUTION

Do not block the air vent on the GLT400, as this will cause malfunctioning.

Measurement accuracy may not be satisfactory if the system is used in a condition other than described above.

1.4 Notes on Temperature Measurement

Please observe the following precautions when performing temperature measurement.

Do not block the air vents. Always provide a space of at least 30 cm on all sides of the GLT400.

For stabilized temperature measurement, allow the GLT400 to warm up for at least 30 minutes after turning it on.

Exposure of the input terminals to direct drafts, direct sunlight, or abrupt changes in temperature may impair the equilibrium of the input parts and result in measurement errors. To measure temperature in such an environment, take appropriate countermeasures such as changing the installation site of the GLT400.

To conduct measurement in noisy environments, connect the GLT400's GND terminal to ground (Refer to "2.17 Noise Countermeasures").

If measured values fluctuate due to noise, set to a slower sampling speed (Refer to "Chapter 4 Settings and Measurement" – "4.3 Settings screen" – "(3) DATA Settings").

CHAPTER 2 Checks and Preparation

This chapter explains how to check the GLT400's external casing and accessories, and how to prepare the GLT400 for operation.

PRODUCT SUMMARY

- 2.1 Checking the Outer Casing***
- 2.2 Checking the Accessories***
- 2.3 Nomenclature and Functions***
- 2.4 How to Install Expansion Terminal Base (option)***
- 2.5 How to Remove Expansion Terminal Base***
- 2.6 How to Connect Expansion Terminal Connection Cable (option)***
- 2.7 How to Install Multiple Expansion Terminal Bases (option)***
- 2.8 Connecting the Power Cable and Turning on the Power***
- 2.9 Power Connection with USB PD***
- 2.10 Connecting the Signal Input Cables***
- 2.11 Logic Alarm Cable Connection and Functions***
- 2.12 Mounting the SD CARD***
- 2.13 Installing the Wireless Unit (B-568: option)***
- 2.14 Connecting to a PC***
- 2.15 Connecting the Humidity Sensor (option)***
- 2.16 Precautions to Observe When Performing Measurement***
- 2.17 Noise Countermeasures***
- 2.18 When Fixing the GLT400 Body***

2.1 Checking the Outer Casing

After unpacking, check the GLT400's outer casing before use. In particular, please check for the following:

- Surface scratches
- Other flaws such as stains or dirt

2.2 Checking the Accessories

After unpacking, check that the following standard accessories are included.

Standard Accessories

Item	Remarks	Quantity
Quick Start Guide	GLT400-UM-85x	1
AC cable/AC adapter	100 to 240 VAC, 50/60 Hz	1
Spacer	Large: 1, Small: 2 (Used when the terminal base is installed.)	1 set
TO ENSURE SAFE AND CORRECT USE	SAFETY PAMPHLET	1

2.3 Nomenclature and Functions

This section describes the names and function of parts of the GLT400.

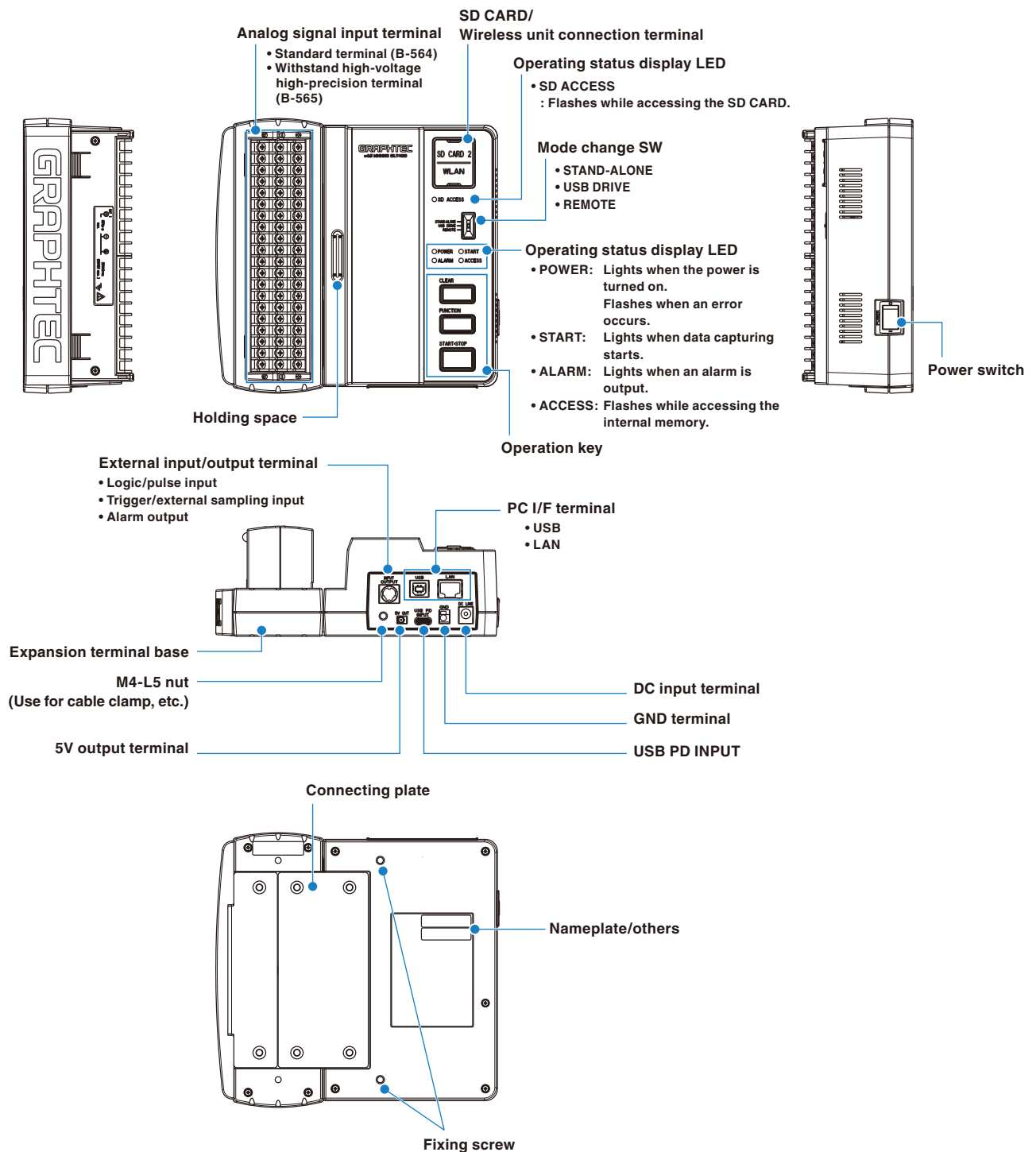

Screwless terminal (B-564SL)

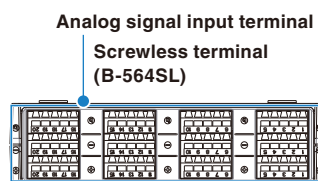

2.4 How to Install Expansion Terminal Base (option)

This section describes how to install the expansion terminal base.

CAUTION

When installing the expansion terminal base to the GLT400, please make sure that the GLT400 power is off.

Prepare the expansion terminal base (sold separately) and the spacer that supplied in the GLT400.

B-566 Expansion terminal base

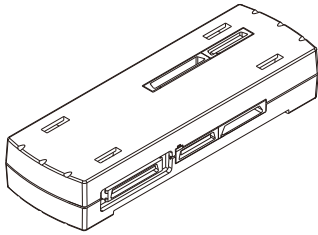

Expansion terminal base: 1 pc.

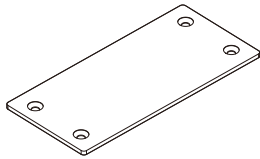

Connecting plate: 1 sheet



M4x6 flat screw: 4 pcs.

Spacer (supplied in the GLT400)

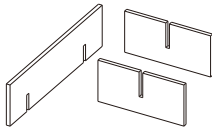

Spacer: 1 set

How to install

(1) Install the connecting plate and the cover to the expansion terminal base with the supplied screws.

* Recommended tightening torque: 14 kgf/cm

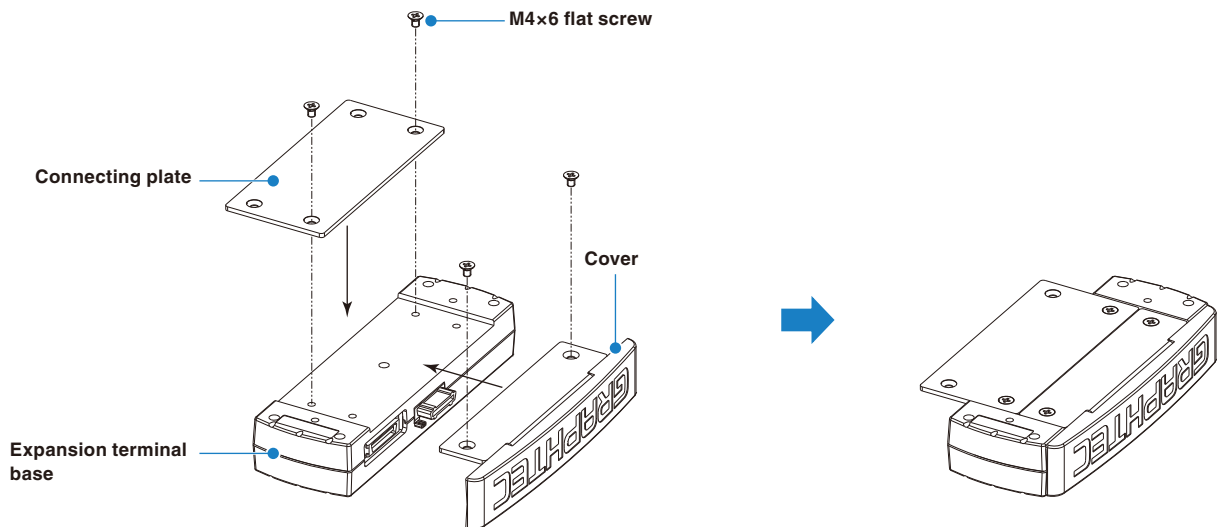

(2) Install it to the GLT400.

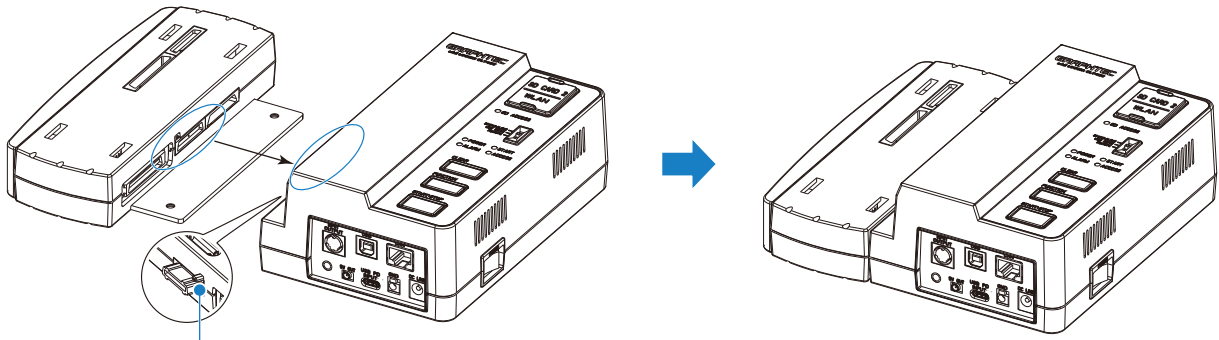

* Pay attention to the protrusions when direct-connecting.

CAUTION

Please direct-connect the extension terminal bases carefully so as not to bend the protrusions next to the connector.

Please handle the GLT400 in a horizontal state until the extension terminal bases are fixed with the connecting plate.

(3) Assemble the spacer.

Place the GLT400 to which the expansion terminal base is attached on the spacer without rattling.

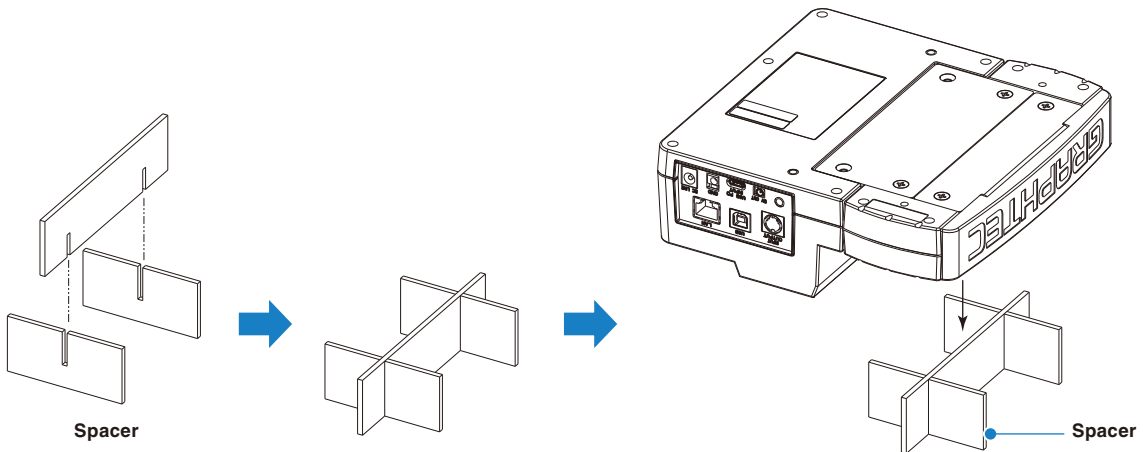

(4) Attach it with the supplied screws.

* Recommended tightening torque: 14 kgf/cm

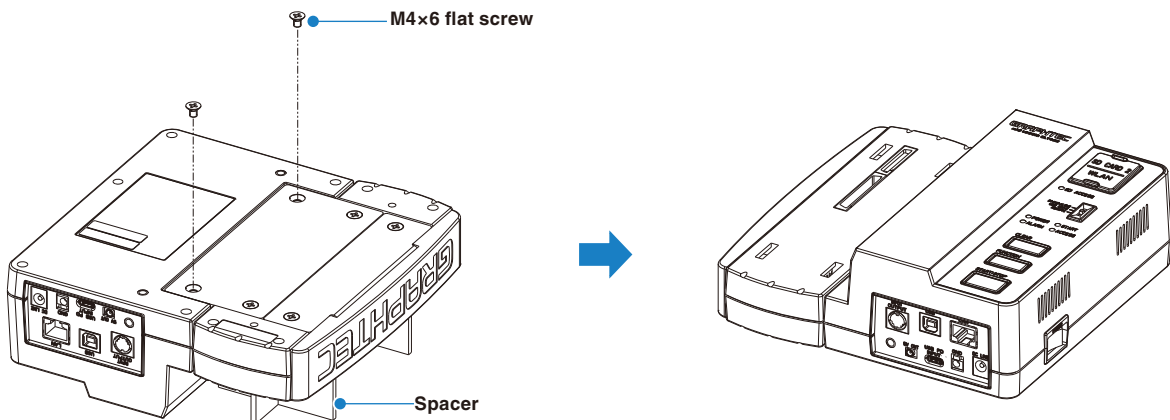

- (5) Insert the claw at the top of the terminal into the groove on the expansion terminal base and push the terminal in until the claw at the bottom of the terminal is completely locked.

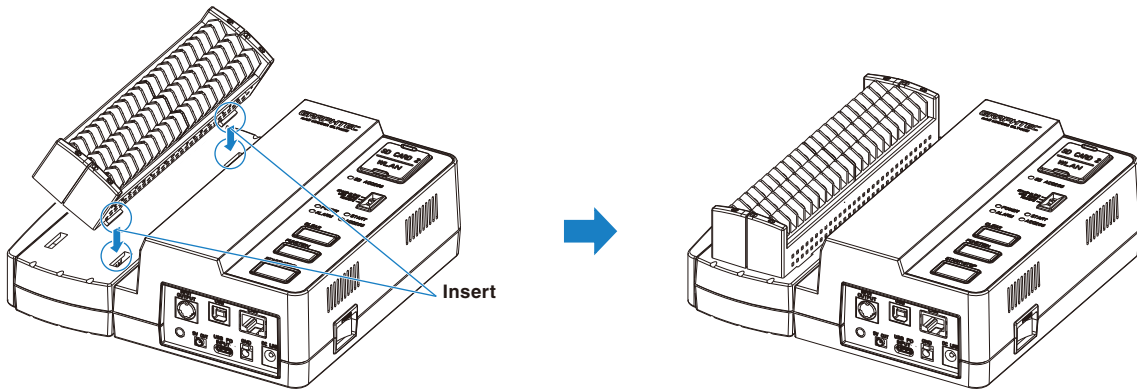

CAUTION

For the withstand high-voltage high-precision terminal (B-565), push it in while pulling it toward you.

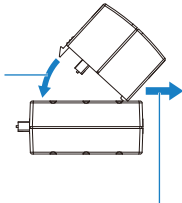

* Push in while pulling in toward you.

2.5 How to Remove Expansion Terminal Base

This section describes how to remove the standard terminal or the withstand high-voltage high-precision terminal.

The screwless terminal can be removed in the same way.

CAUTION

When removing the standard terminal, the withstand high-voltage high-precision terminal or the screwless terminal from the GLT400, please make sure that the GLT400 power is off.

How to remove

- (1) Pull out the terminal in the direction of the arrow while pushing the two locks (locations) under the standard terminal, the screwless terminal or the withstand high-voltage high-precision terminal.

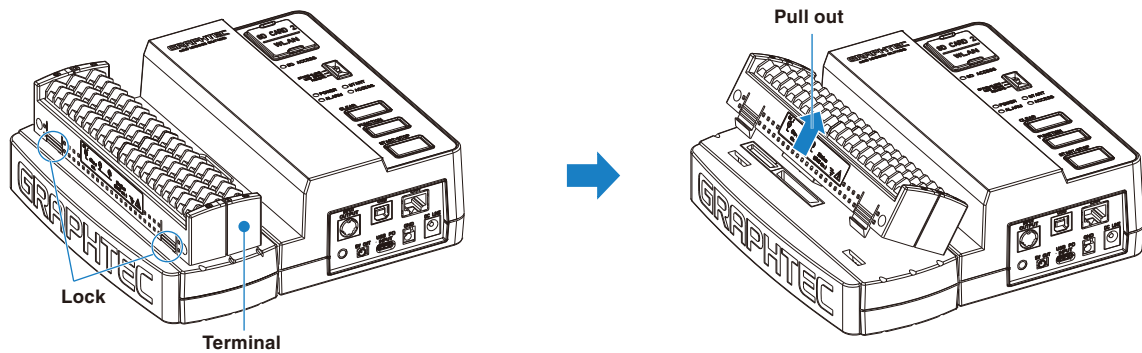

- (2) Remove the terminal.

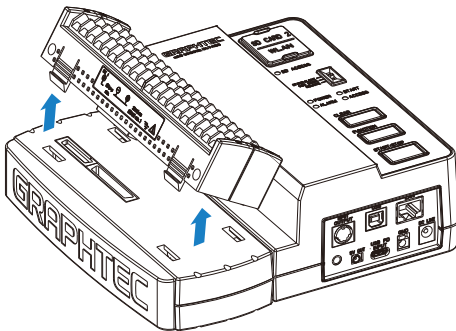

(3) Assemble the spacer.

Place the GLT400 to which the expansion terminal base is attached on the spacer without rattling.

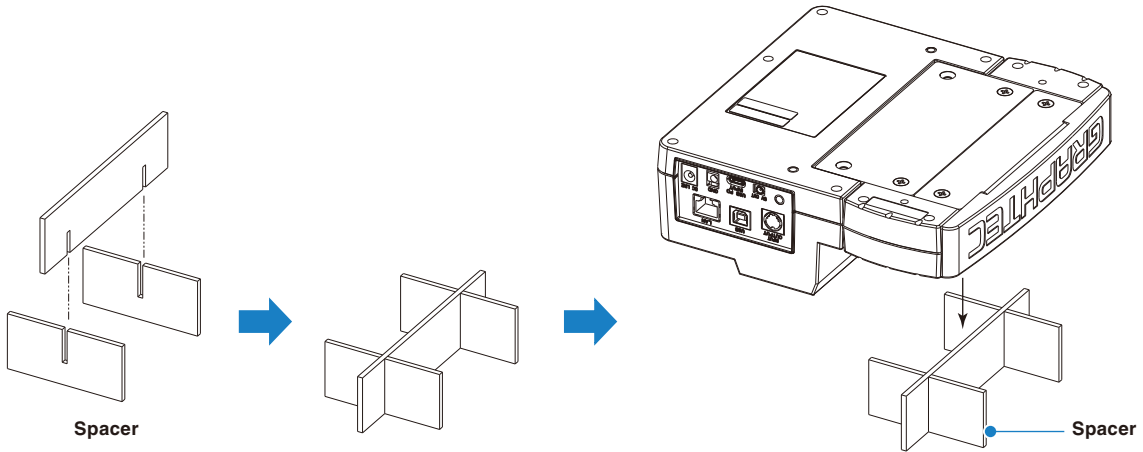

(4) Remove the screw.

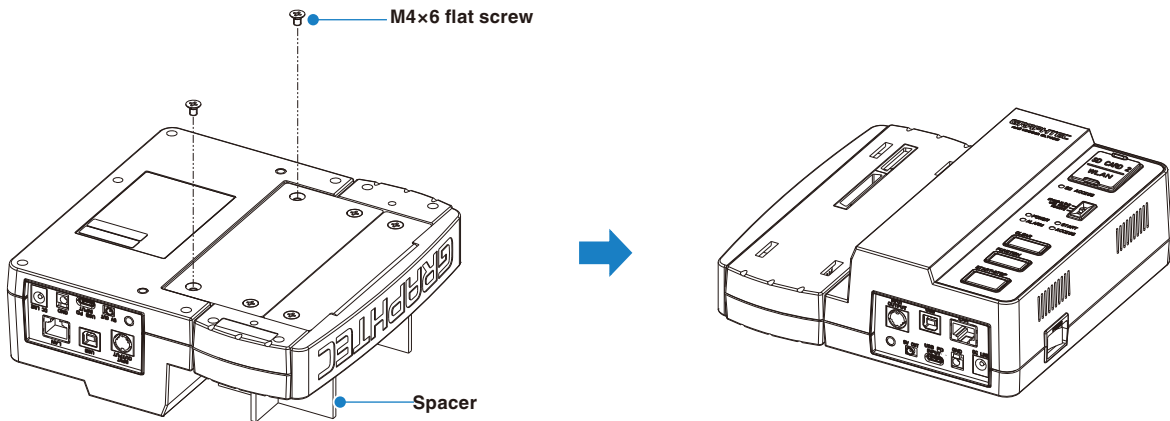

(5) Remove the terminal from the GLT400.

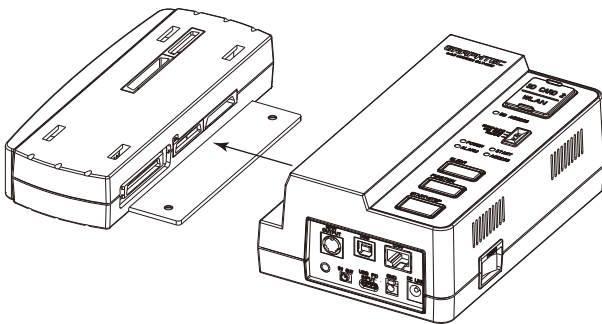

2.6 How to Connect Expansion Terminal Connection Cable (option)

This section describes how to connect the expansion terminal connection cable.

CAUTION

When connecting the expansion terminal connection cable to the GLT400, please make sure that the GLT400 power is off.

Prepare an expansion terminal connection cable (sold separately).

B-567 Expansion terminal connection cable (Select from 2 types)

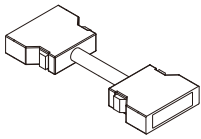

Expansion terminal connection cable: 1 pc.
(50 cm: B-567-05)

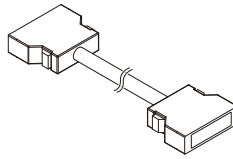

Expansion terminal connection cable: 1 pc.
(2 m: B-567-20)

How to install

- (1) Insert the claw at the top of the terminal into the groove on the expansion terminal base and push the terminal in until the claw at the bottom of the terminal is completely locked.

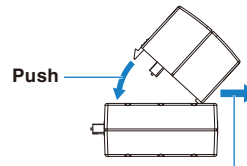
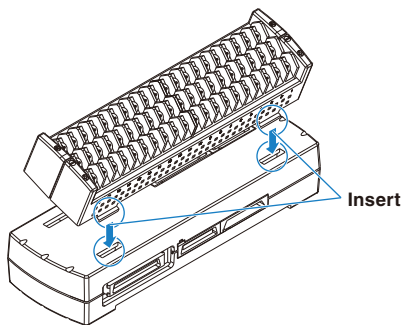

* For the withstand high-voltage high-precision terminal (B-565), push it in while pulling it toward you.

- (2) Connect the expansion terminal connection cable to the expansion terminal base.

* Push the expansion terminal connection cable until it is completely locked.

* Connect according to the connector shape.

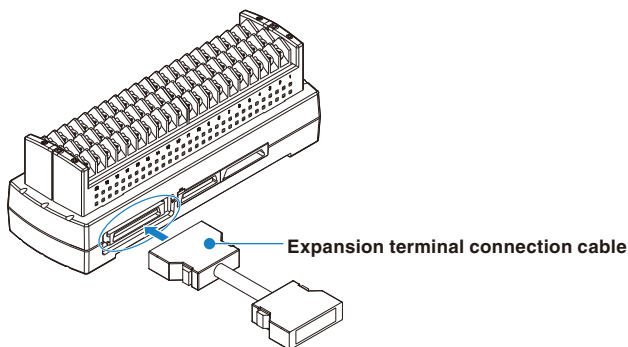

(3) Connect the other end of the expansion terminal connection cable to the terminal connector on the GLT400.

* Push the expansion terminal connection cable until it is completely locked.

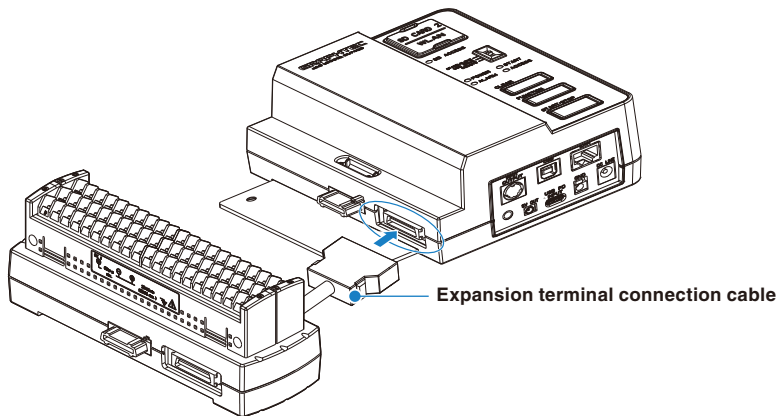

CAUTION

How to disconnect the expansion terminal connection cable

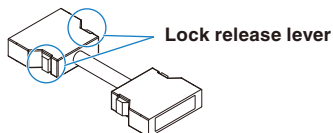

When disconnecting the expansion terminal connection cable from the GLT400 or the expansion terminal base, please note the following:

- Always pull out the cable straightly while pushing the lock release levers on both sides.
- Do not forcibly disconnect, or do not forcibly pull out the cable while pushing the lock release lever of the one side only.

Please note that this may cause a poor connection of the connector.

2.7 How to Install Multiple Expansion Terminal Bases (option)

This section describes how to install multiple expansion terminal bases.

CAUTION

When direct-connecting the expansion terminal base to the GLT400 or connecting the expansion terminal connection cable, please make sure that the GLT400 power is off.

Prepare the expansion terminal base (sold separately) and the expansion terminal connection cable.

B-566 Expansion terminal base

Prepare the same number of expansion terminal bases as the standard terminals, high-voltage high-precision terminals or screwless terminals to be added.

B-567 Expansion terminal connection cable (Select from 2 types)

Prepare one expansion terminal connection cable (50 cm: B-567-05) or one expansion terminal connection cable (2 m: B-567-20).

In addition, when connecting the expansion terminal base and the expansion terminal base apart, prepare the required number of cables.

* When all expansion terminal bases and GLT400 are direct-connected, no expansion terminal connection cable is required.

When direct-connecting

(1) Direct-connect the expansion terminal bases and attach the connecting plate and the cover with the supplied screws.

* Recommended tightening torque: 14 kgf/cm

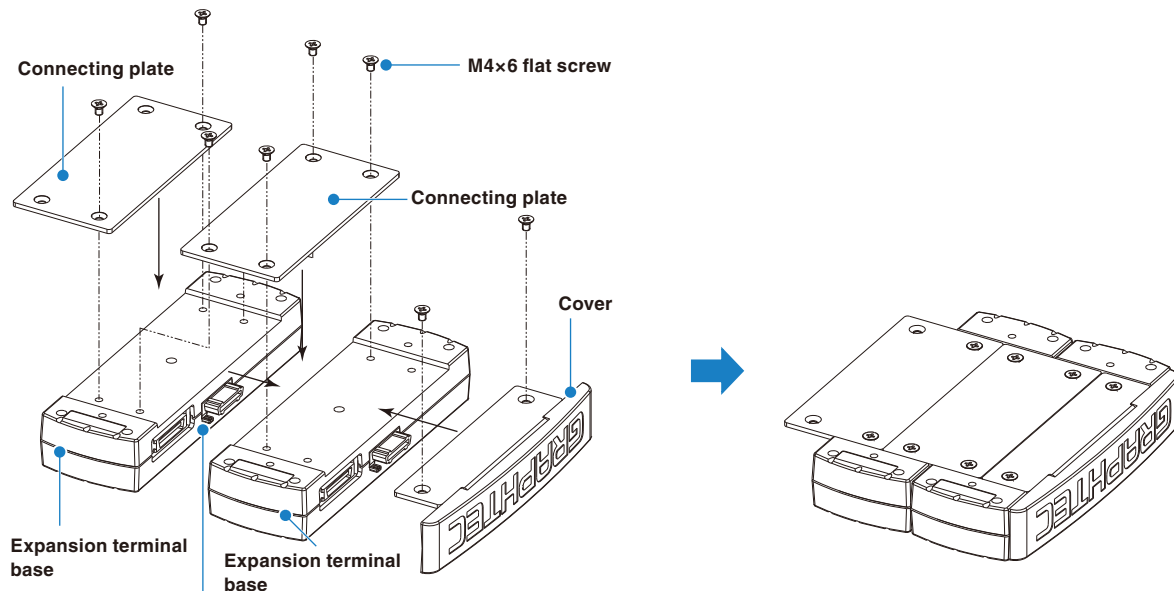

* Pay attention to the protrusions when direct-connecting.

CAUTION

Please direct-connect the extension terminal bases carefully so as not to bend the protrusions next to the connector.

Please handle the GLT400 in a horizontal state until the extension terminal bases are fixed with the connecting plate.

- (2) Attach the expansion terminal base to the GLT400.

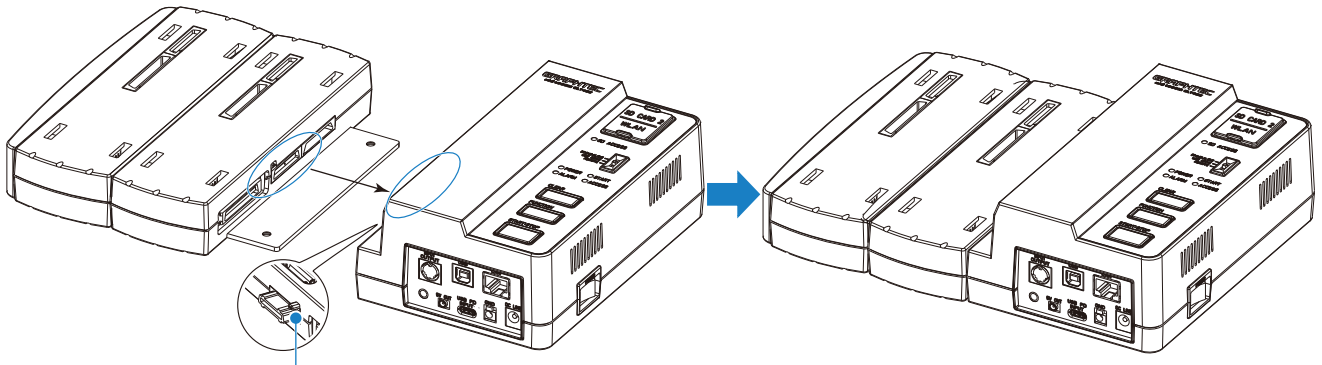

* Pay attention to the protrusions when direct-connecting.

CAUTION

Please direct-connect the extension terminal bases carefully so as not to bend the protrusions next to the connector.

Please handle the GLT400 in a horizontal state until the extension terminal bases are fixed with the connecting plate.

- (3) Install it with the supplied screws.

Hold the expansion terminal base at a height of 33 to 34 mm, align the height of the expansion terminal base with the height of the GLT400, and tighten the screws.

* Recommended tightening torque: 14 kgf/cm

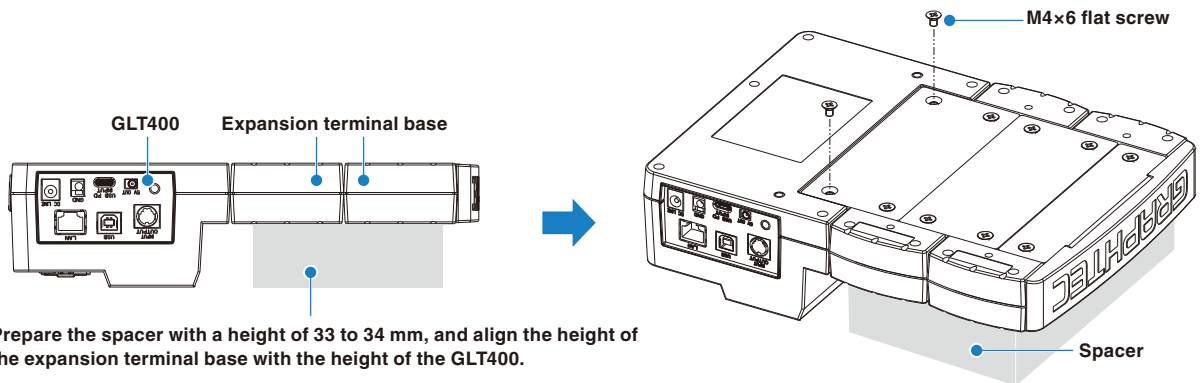

Prepare the spacer with a height of 33 to 34 mm, and align the height of the expansion terminal base with the height of the GLT400.

CAUTION

If the height of the GLT400 and the expansion terminal base are not aligned, the direct-connected connector may be damaged due to the load applied to the connector.

- (4) Insert the claw at the top of the terminal into the groove on the expansion terminal base and push the terminal in until the claw at the bottom of the terminal is completely locked.

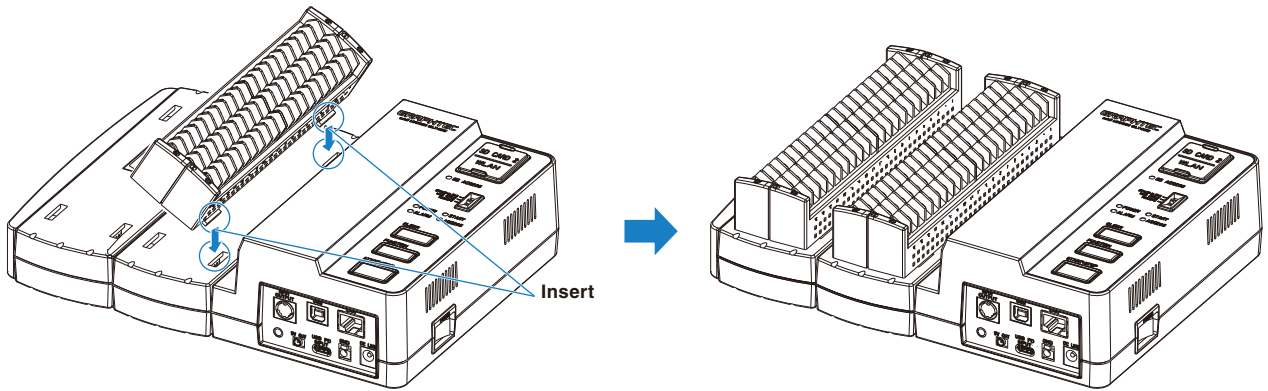

CAUTION

For the withstand high-voltage high-precision terminal (B-565), push it in while pulling it toward you.

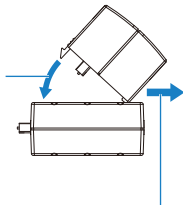

* Push in while pulling it toward you.

When connecting with the cable

- (1) Direct-connect the expansion terminal bases and attach the connecting plate and the cover with the supplied screws.

* Recommended tightening torque: 14 kgf/cm

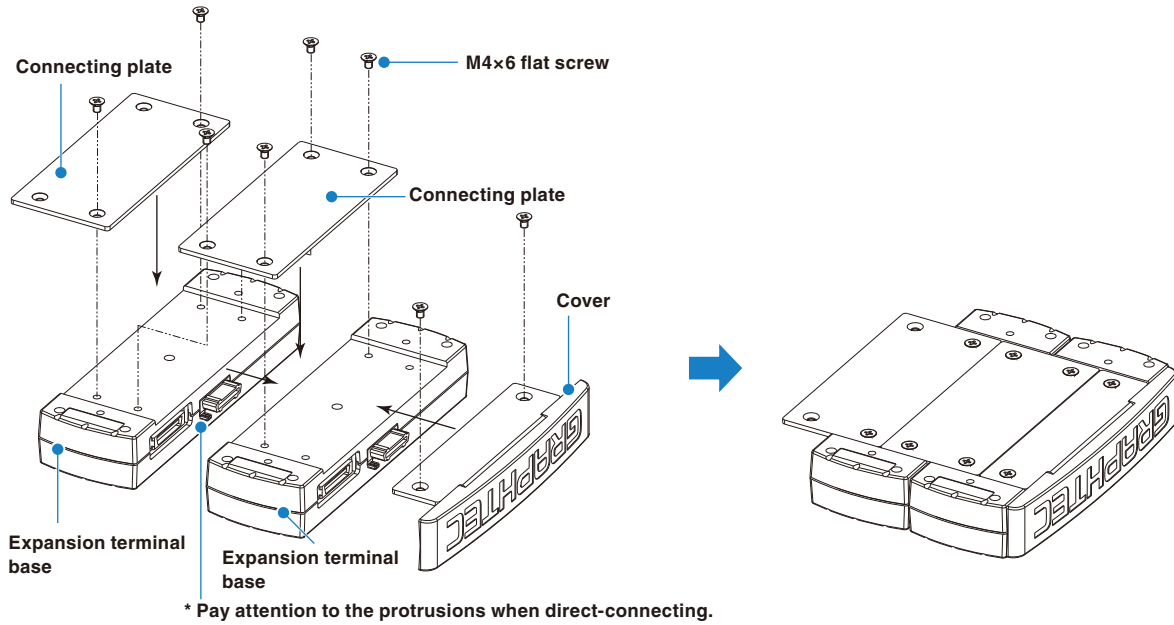

CAUTION

Please direct-connect the extension terminal bases carefully so as not to bend the protrusions next to the connector.

Please handle the GLT400 in a horizontal state until the extension terminal bases are fixed with the connecting plate.

- (2) Insert the claw at the top of the terminal into the groove on the expansion terminal base and push the terminal in until the claw at the bottom of the terminal is completely locked.

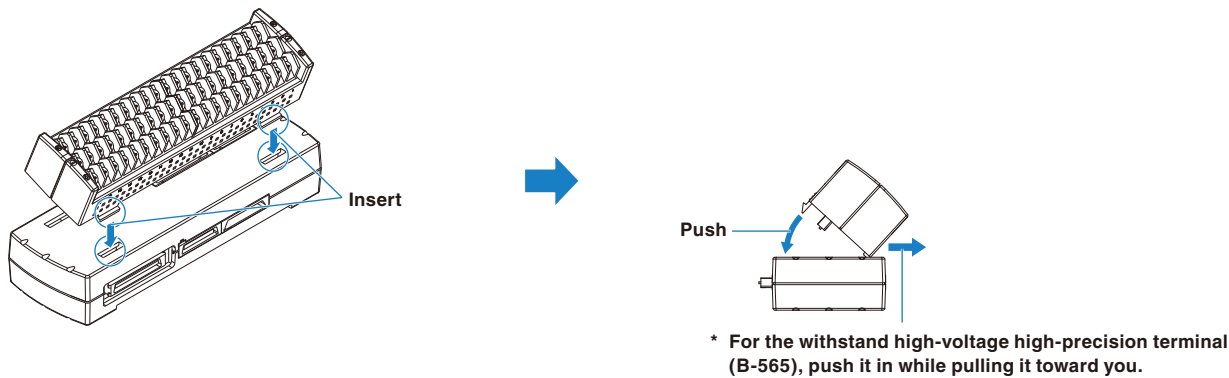

- (3) Connect the expansion terminal connection cable to the expansion terminal base.
- * Push the expansion terminal connection cable until it is completely locked.
 - * Connect according to the connector shape.

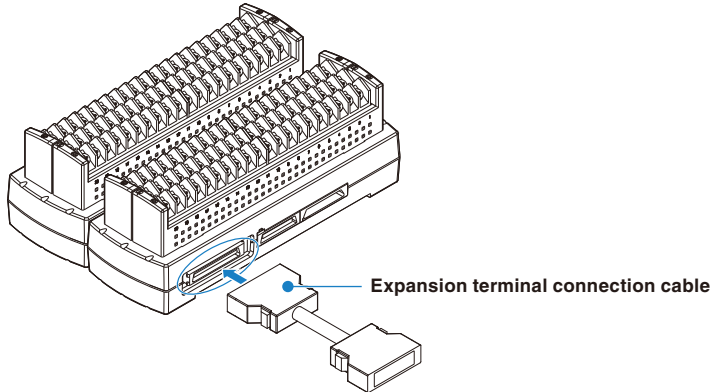

- (4) Connect the other end the expansion terminal connection cable to the terminal connector on the GLT400.
- * Push the expansion terminal connection cable until it is completely locked.

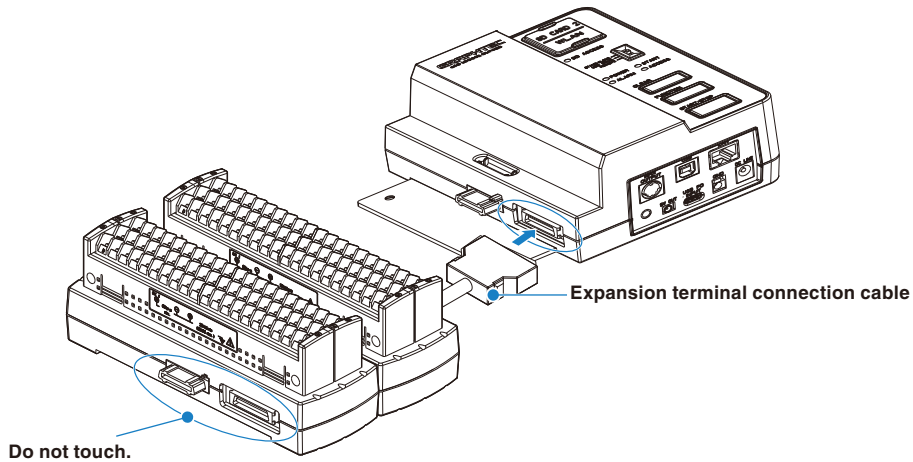

CAUTION

When a signal is input to the expansion terminal base, do not touch the pins of the connector or the protrusions next to the connector.

CAUTION

How to disconnect the expansion terminal connection cable

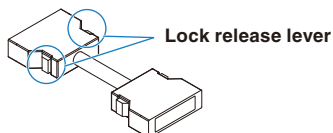

When disconnecting the expansion terminal connection cable from the GLT400 or the expansion terminal base, please note the following:

- Always pull out the cable straightly while pushing the lock release levers on both sides.
- Do not forcibly disconnect, or do not forcibly pull out the cable while pushing the lock release lever of the one side only.

Please note that this may cause a poor connection of the connector.

When adding the terminals

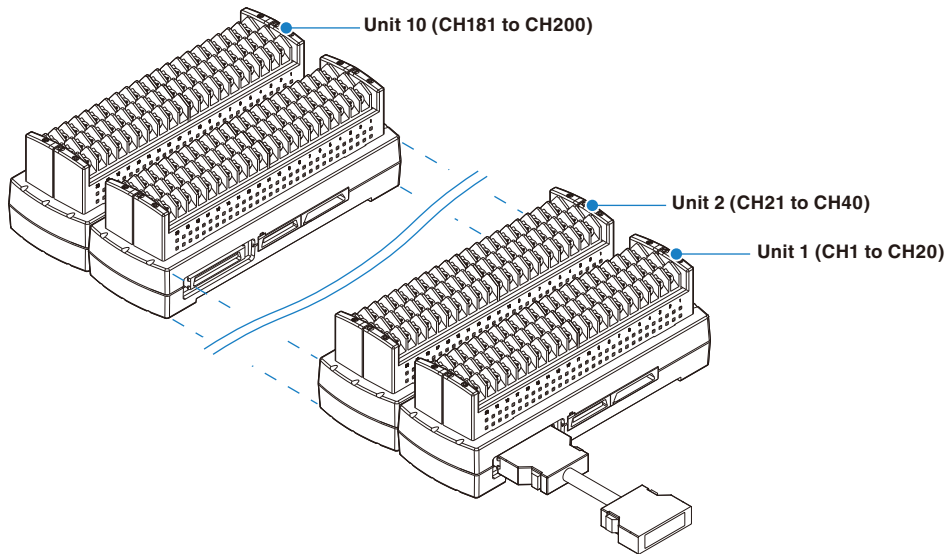

CAUTION

When adding the terminals, connect them continuously without omitting the terminals in between. If you omit the terminal in between, the terminals after that is not recognized.

When using the standard terminal or the screwless terminal in combination with the high-voltage, high-precision terminal, the withstand voltage must conform to the specifications of the standard or screwless terminal.

When using the GL800 or GL820 terminal in combination, the temperature measurement accuracy may not meet the specifications.

When connecting with the expansion terminal connection cable

- (1) Connect between the expansion terminal bases with the expansion terminal connection cable.
 - * Push the expansion terminal connection cable until it is completely locked.
 - * Connect according to the connector shape.

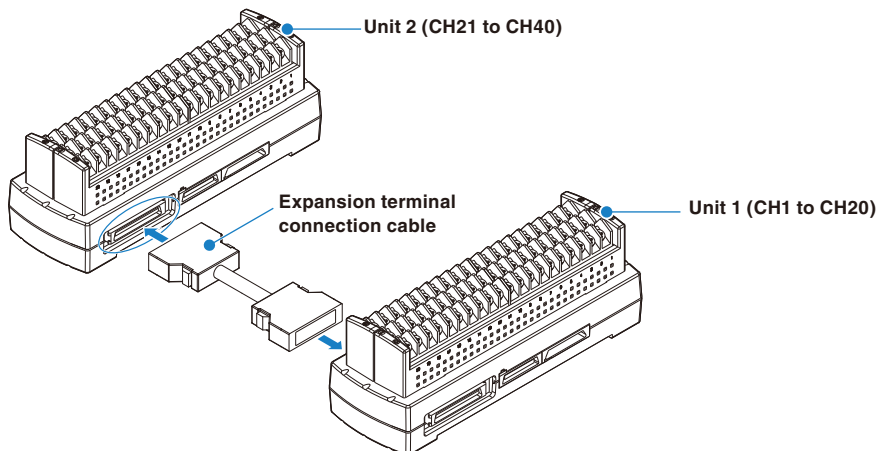

- (2) Connect between the expansion terminal bases with the expansion terminal connection cable.
- * Push the expansion terminal connection cable until it is completely locked.
- Install the extension terminal bases in a stable location and be careful not to fall.

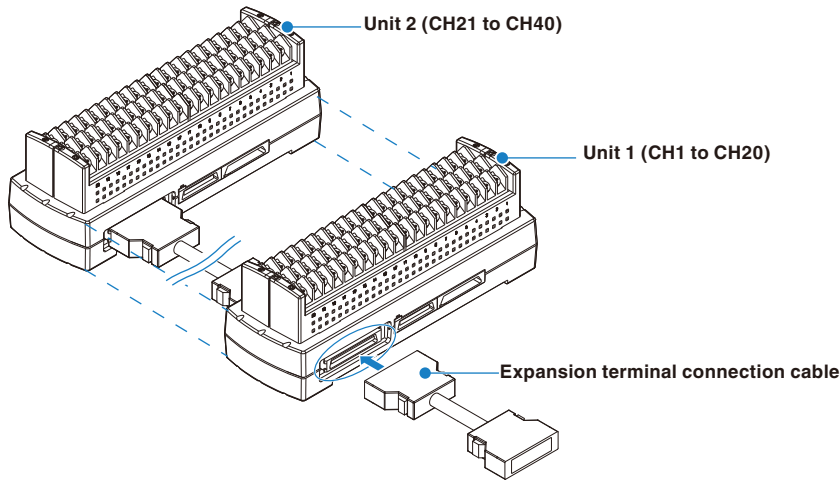

- (3) Connect the other end the expansion terminal connection cable to the terminal connector on the GLT400. Push the expansion terminal connection cable until it is completely locked.

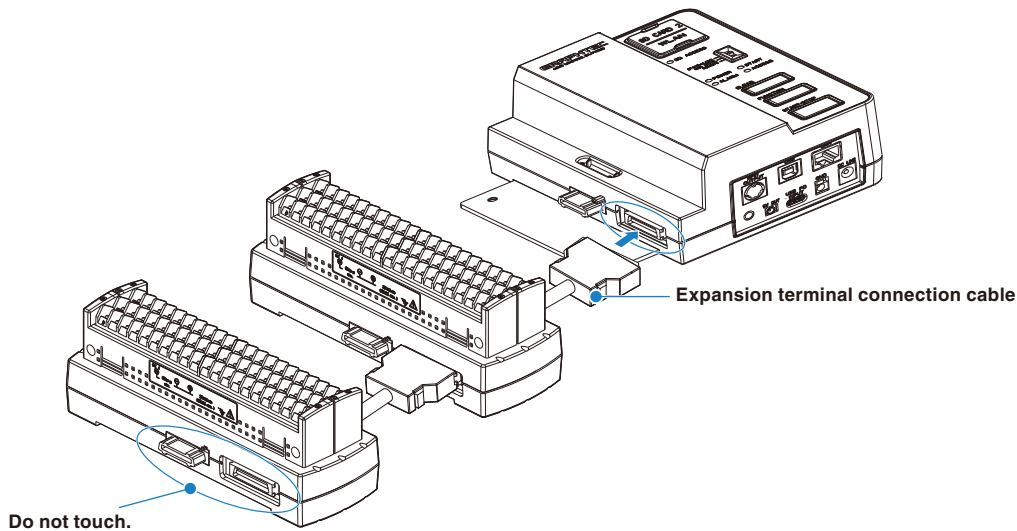

CAUTION

When a signal is input to the connected terminal, do not touch the pins of the connector or the terminal next to the connector.

When disconnecting the expansion terminal connection cable from the GLT400 or the expansion terminal base, please note the following:

- Always pull out the cable straightly while pushing the lock release levers on both sides.
- Do not forcibly disconnect, or do not forcibly pull out the cable while pushing the lock release lever of the one side only.

Please note that this may cause a poor connection of the connector.

When the expansion terminal connection cable is used, it is easily affected by noise.

When the GLT400 is affected by noise, reduce the sampling rate.

CAUTION

When adding the terminals, connect them continuously without omitting the terminals in between. If you omit the terminal in between, the terminals after that is not recognized.

When using the standard terminal or the screwless terminal in combination with the high-voltage, high-precision terminal, the withstand voltage must conform to the specifications of the standard or screwless terminal.

When using the GL800 or GL820 terminal in combination, the temperature measurement accuracy may not meet the specifications.

2.8 Connecting the Power Cable and Turning on the Power

This section describes how to connect the power cable and turn on the power. The connection method will vary depending on the type of power supply used.

Connecting to an AC Power Supply

Use the AC cable and AC adapter that are provided as accessories.

CAUTION

Be sure to use the AC adapter that is supplied as a standard accessory.

When using in an environment of -20°C to 0°C or 45°C to 60°C , use the following AC adapter.

Recommended product (as of July 2020)

- Manufacturer: TOKI Trading Ltd. (<https://toki-t.com>)
- Product name: IPU25A-108 24V

- (1) Plug the AC cable into the AC adapter.

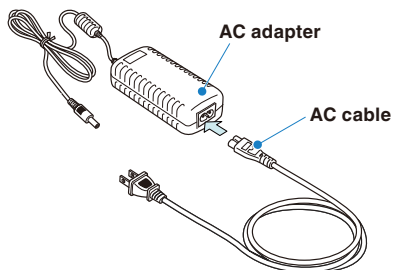

- (2) Connect the output side of the AC adapter to the connector on the GLT400.

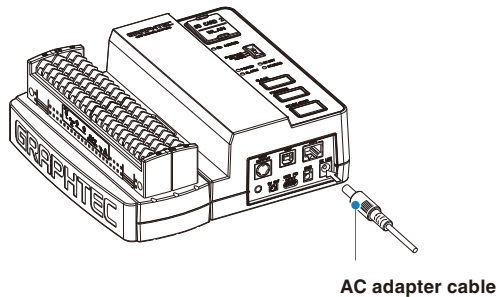

- (3) Using the flat-blade screwdriver, connect the grounding cable to the GLT400 while pressing against the minus (-) button above the GND terminal. Connect the other end of the cable to ground.

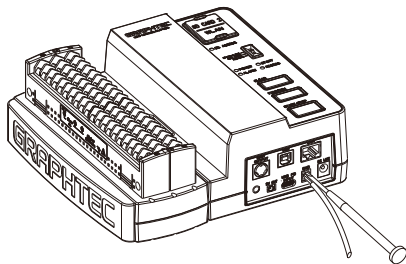

- (4) Plug the AC cable into the mains power outlet.

- (5) Press the power switch on the GLT400 to the ON side to turn on the power.
-

⚠ CAUTION

Always connect the GND terminal and refer to the safety precautions.
The GLT400 must be grounded even when connected to other devices and sharing a common ground level.

Connecting to a DC Power Supply

Use the optional DC drive cable (B-514).

⚠ CAUTION

Use a power supply within the 8.5 to 26.4 VDC range.
For DC drive cable, please be sure to use the B-514.

- (1) Arrange the tip of the DC drive cable (B-514: 2 m) to enable it to be connected to the DC power supply.
(2) Connect the DC output side to the power supply connector on the GLT400.

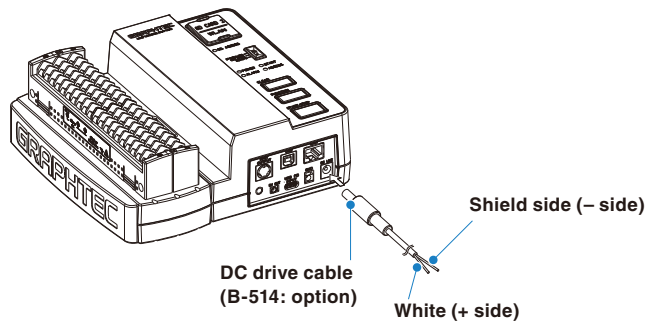

- (3) Connect the DC input side to the DC power supply.
-

⚠ CAUTION

Be sure to check the polarity of the wire tips when performing wiring.

- (4) Press the power switch on the GLT400 to the ON side to turn on the power.

2.9 Power Connection with USB PD

The GLT400 is equipped with the USB PD power supply function. The AC adapter and USB PD can be connected at the same time with the USB PD alone. The USB PD power supply function is available by combining the separately sold product. Please use it after reading the instruction manual of the separately sold product and the following explanation.

When using the USB PD to supply power, there are two possible connections:

- Battery compatible with USB PD
- AC adapter compatible with USB PD

CAUTION

Only the power supply function is possible with the USB PD connection. The communication function is not available.

For the power supply function, make sure that the power output of the power supply equipment is 5V 2.0A when connecting.

If the power output of the power supply equipment does not meet the above output, the power does not turn on. Check the specifications of the power supply equipment.

When supplying power with the USB PD, please follow the specifications of the power supply equipment.

CHECKPOINT

AC adapter and USB PD can be connected simultaneously, but we do not guarantee proper power backup operation. Always check the power supply operation in advance.

The GLT400 complies with USB Power Delivery Revision 2.0. Use the USB PD device that complies with Revision 2.0 or later when connecting it to the GLT400.

For the USB PD cable, use the "Full Featured Type-C cable" or "USB 2.0 Type-C cable" that complies with USB Type-C.

The USB PD cable without the e-maker for connection does not have to use, but it is recommended that you use a reliable manufacturer's product.

The GLT400 complies with EMC directives only when using shielded cables. Use a shielded USB PD cable when using for connection.

Always check the specifications of the power supply equipment. Depending on the connection cable, the power may be cut off during use.

Recommended product (as of July 2020)

- Manufacturer: SANWA SUPPLY INC. (JAPAN)
- Product name: KU-CC series

- (1) Connect the USB PD cable to the power connector of the GLT400.

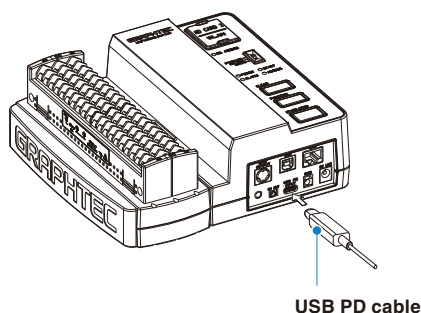

2.10 Connecting the Signal Input Cables

This section describes how to connect the signal input cables.

WARNING

During wiring, confirm that the signal's supply source is turned OFF to prevent electrical shocks. Also, position the GLT400 input cable away from any power lines and ground cables.

Terminal Arrangement and Signal Types

(Standard terminal: B-564, Withstand high-voltage high-precision terminal: B-565)

Terminal assignment of standard terminal and Withstand high-voltage high-precision terminal is common.

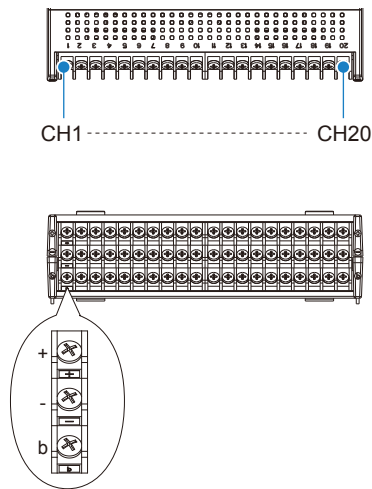

Connection diagram

(Standard terminal: B-564, Withstand high-voltage high-precision terminal: B-565)

DC voltage input

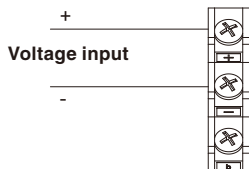

Thermocouple input

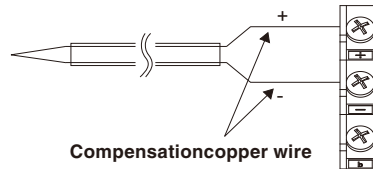

Resistance temperature detector input

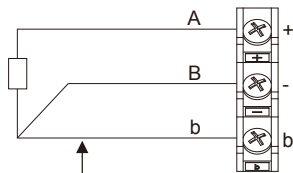

Lead wire resistance should be 10Ω or less per wire, three wires need to be same length.

DC current input

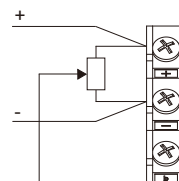

Shunt resistor

Ex: For 4 to 20mA current input, installing 250 ohms (0.1%) resistor for converting 1 to 5V.

* 250 ohms shunt register is the option B551.

+High-voltage terminal (terminal for high-voltage input signals)

-Low-voltage terminal (terminal for low-voltage input signals)

bDedicated terminal when connecting resistance bulb

* Resistance bulb input terminals A (+) and B (-) are isolated within each channel. Terminal b is shorted within all channels.

Item	Description
Input configuration	Isolated input, scanning
Measurement range	20, 50, 100, 200, 500 mV/F.S.; 1, 2, 5, 10, 20, 50, 100 V/F.S.; 1-5V
Thermocouples	K, J, E, T, R, S, B, N, C (WRe 5-26)
Resistance temperature detector	Pt100, JPt100, Pt1000 (IEC751)
A/D resolution	16-bit (Effective resolution: Approx. 1/40,000 of the +/- range)
Filter	Off, 2, 5, 10, 20, 40 Filter operation is on a moving average basis. The average value of the set sampling count is used. If the sample interval exceeds 30 seconds, the average value of data obtained in a sub-sample (30 seconds) is used.

Terminal arrangement and signal type (Screwless terminal: B-564SL)

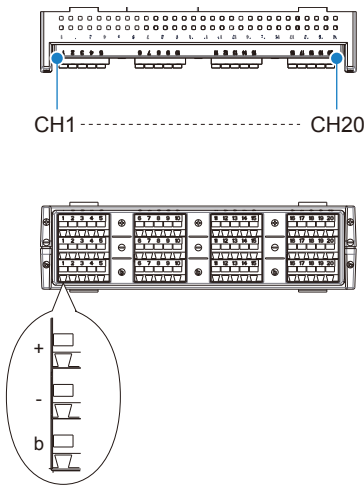

Wiring diagram (Screwless terminal: B-564SL)

DC voltage input

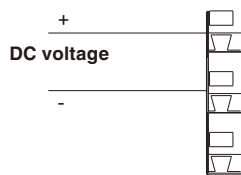

Thermocouple input

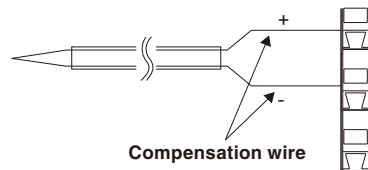

Resistance bulb input

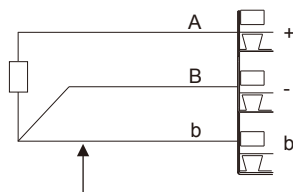

The lead wire resistance per line should be 10Ω or less, and the resistance values of the three lines should be equal.

DC current input

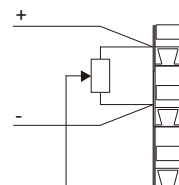

Shunt resistance
Example: For 4-20mA, add 250Ω (± 0.1%) and measure in the 1 - 5V range.

- + High-voltage terminal (Terminal for inputting the high-voltage side of the input signal)
- Low-voltage terminal (Terminal for inputting the low-voltage side of the input signal)

bDedicated terminal used to connect the resistance bulb.

* Terminal A (+) and terminal B (–) for the resistance bulb input are insulated for each channel, but the terminal b is short-circuited inside all channels.

Recommended connection: Cable diameter (): 0.3 to 1.3 mm

Item	Description
Input configuration	Isolated input, scanning
Measurement range	20, 50, 100, 200, 500mV/F.S.; 1, 2, 5, 10, 20, 50, 100V; 1-5V/F.S
Thermocouple	K, J, E, T, R, S, B, N, C (WRe5-26)
Resistance bulb	Pt100, JPt100, Pt1000 (IEC751)
A/D resolution	16Bit (Effective resolution: approx. 1/40,000 of ± range)
Filter	Off, 2, 5, 10, 20, 40 Filter operation is on a moving average basis. The average value of the set sampling count is used. If the sample interval exceeds 30 seconds, the average value of data obtained in a sub-sample (30 seconds) is used.

2.11 Logic Alarm Cable Connection and Functions

This section describes how to connect the logic alarm cables and the functions of cable.

WARNING

During wiring, confirm that the signal's supply source is turned OFF to prevent electrical shocks.
Also, position the GLT400 input cable away from any power lines and ground cables.

The input/output cable (B-513: option) enables logic/pulse input, external trigger input, and alarm signal output.

Connect the input/output cable (B-513: option) to the external input/output terminal as shown below.

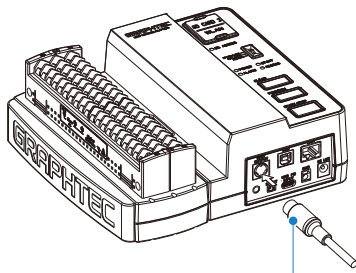

Input/output cable
(B-513: option)

Logic/Pulse Input Specifications

Item	Description
Number of input channels	4
Input voltage range	0 to +30 V max. (single-ended ground input)
Threshold level	Approx. +2.5 V
Hysteresis	Approx. 0.5 V (+2.5 to +3 V)

* Switch between logic and pulse input.

Trigger Input/External Sampling Input Specifications

Item	Description
Number of input channels	1
Input voltage range	0 to +30 V max. (single-ended ground input)
Threshold level	Approx. +2.5 V
Hysteresis	Approx. 0.5 V (+2.5 to +3 V)

Alarm Output Specifications

Item	Description
Number of Output channels	4
Output format	Open collector output +5 V, Pull-up resistance 10 K Ω * See the next page for details on alarm output

CAUTION

When the power is turned OFF or ON, the GLT400 temporarily becomes the alarm state.

CHECKPOINT

Logic/pulse is not available when the operating mode is REMOTE.

The alarm is output from only one channel when the operating mode is REMOTE.

Internal equivalent circuit of I/O circuit

● Alarm output

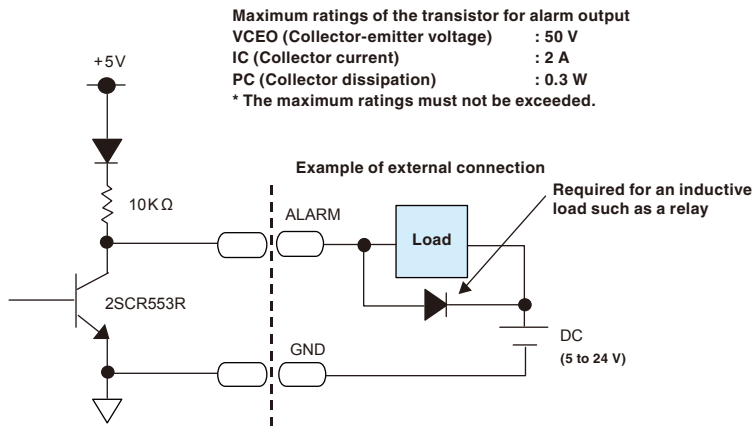

● Logic/pulse input

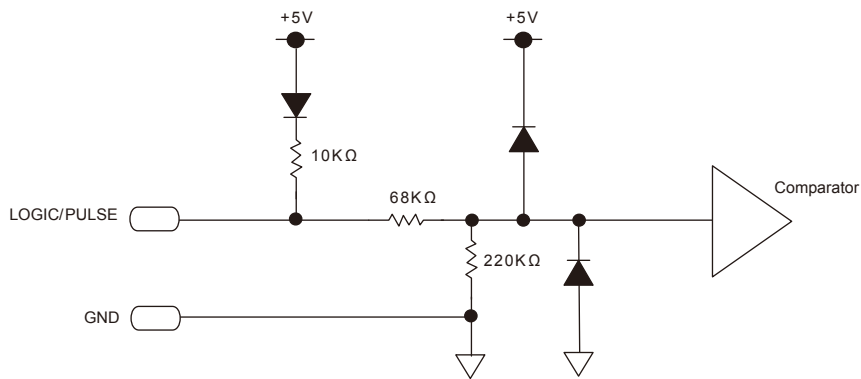

● Trigger input/external sampling input

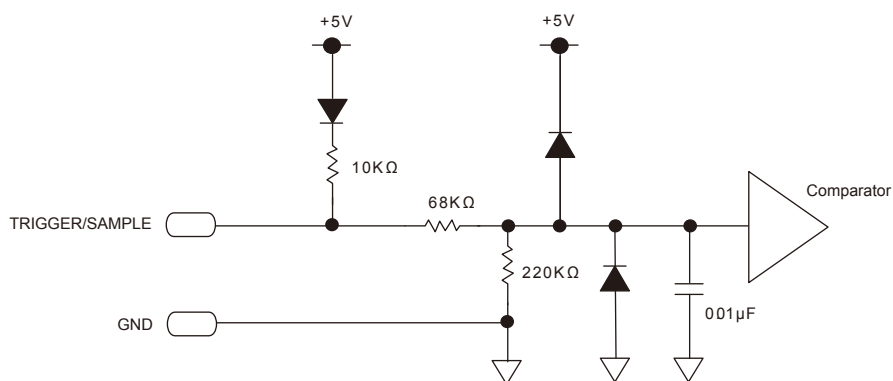

Wiring

Cable tips are bare tips. Perform wiring for the necessary functions.

Signal Name	Channel Number	Wire Color
Logic/Pulse Input	1	Orange with red dotted line
	2	Orange with black dotted line
	3	Grey with red dotted line
	4	Grey with black dotted line
Alarm output	1	White with red dotted line
	2	White with black dotted line
	3	Yellow with red dotted line
	4	Yellow with black dotted
Trigger input/External sampling input		Pink with red dotted line
GND		Pink with black dotted line
		Shielded

* Switch between logic and pulse.

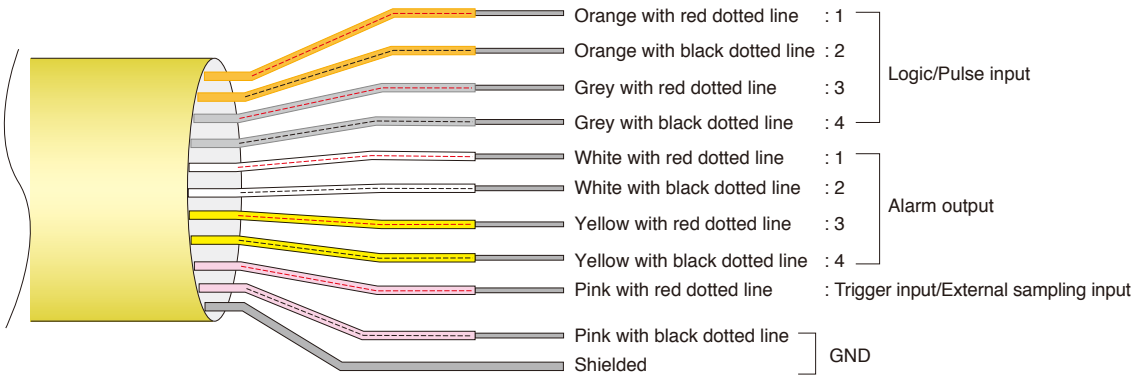

2.12 Mounting the SD CARD

⚠ CAUTION

- When the SD CARD is inserted, make sure that the card is not locked. If locked, the data cannot be captured.
- Do not remove the SD CARD while accessing the SD CARD (When the SD ACCESS LED is lit in "green"). The captured data may be damaged.
- When inserting the large capacity SD CARD, it may take some time to recognize it.

How to insert the SD CARD (SD CARD)

Insert the SD CARD into the SD CARD slot.

⚠ CAUTION

When the optional wireless LAN unit is installed, the SD CARD cannot be inserted.

- (1) Remove the SD CARD protective cover.
 - * Store the protective cover in the holding space.

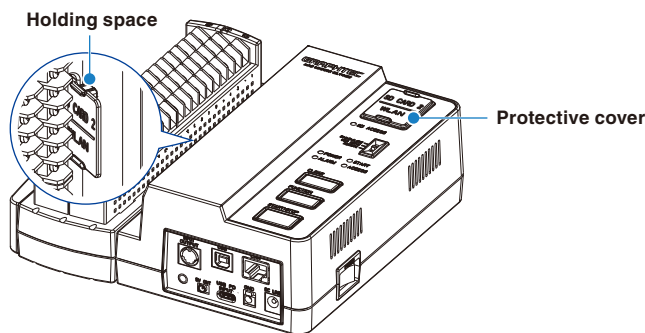

- (2) Insert the SD CARD until it clicks and is locked.
 - * Make sure that the SD CARD is not locked.

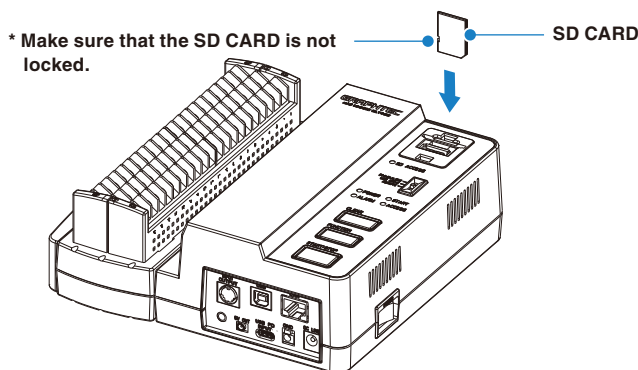

- (3) Insert and close the protective cover into the upper hole and lower hole for the SD CARD protective cover.

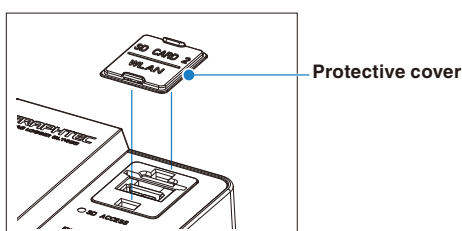

How to remove the SD CARD (SD CARD)

- (1) Remove the SD CARD when the SD CARD is not accessed (SD ACCESS LED is not lit.).
 - (2) Remove the SD CARD protective cover.
 - (3) The SD CARD is unlocked by pushing gently the SD CARD. Then, remove the SD CARD.
-

 **CAUTION**

Do not remove the SD CARD while accessing it.

2.13 Installing the Wireless Unit (B-568: option)

To connect the GLT400 to the wireless LAN, insert the wireless LAN unit in the SD CARD slot.

⚠ CAUTION

- When the SD CARD has been inserted into the SD CARD slot, please remove the SD CARD.
- When the wireless LAN unit has been inserted, the SD CARD cannot be inserted into the SD CARD slot.
- When inserting the wireless LAN unit, please make sure that the power is turned OFF and then install the unit.
- When using the wireless LAN, please check the "3. Notes on Radio Law" in the "Notes on Use" described above.

How to insert the wireless LAN unit

Insert the wireless LAN unit into the SD CARD slot.



Wireless LAN unit
(Option: B-568)

- (1) Turn OFF the GLT400's power.
- (2) Remove the SD CARD protective cover.
 - * Store the protective cover in the holding space.

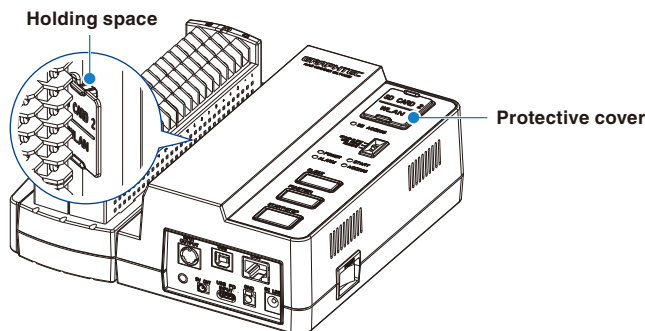

- (3) When the SD CARD has been inserted, remove the SD CARD.
 - * The SD CARD is unlocked by pushing gently the SD CARD. Then, remove the SD CARD.

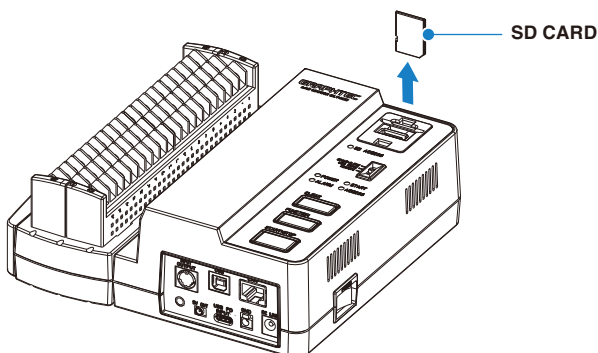

- (4) Align the wireless LAN unit to the wireless unit terminal and the wireless unit fixed guide and then insert the wireless LAN unit until the unit is locked.

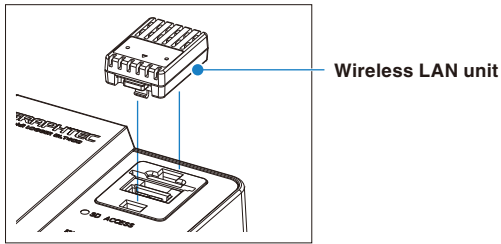

CAUTION

When the wireless LAN unit has been inserted, please be careful when handling so as not to hit and drop.

Removing the wireless LAN unit

Turn OFF the power and then remove the wireless LAN unit.

- (1) Push the lock part on the wireless LAN unit to unlock, and then remove it.

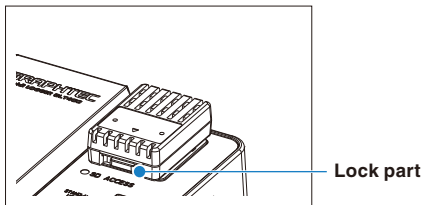

- (2) After removing it, mount the SD CARD protective cover to protect the connectors.

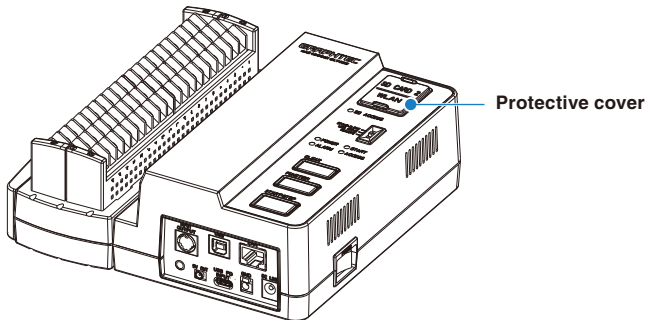

2.14 Connecting to a PC

Use the USB or LAN Interface to connect the GLT400 to a PC.

Connection Using a USB Cable

(1) Connect between the GLT400 and PC with the USB cable.

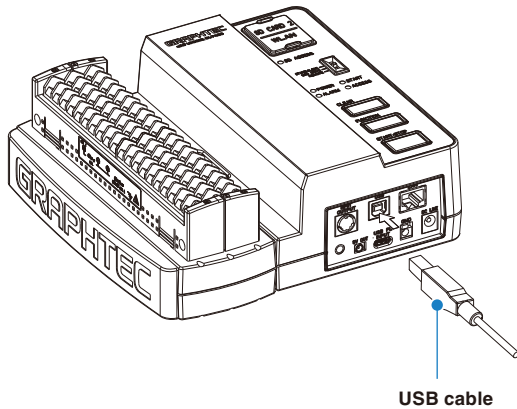

CAUTION

The USB connector is adjacent to the LAN connector. Make sure the cable is inserted into the correct connector.

CHECKPOINT

When connecting with the USB cable, the USB driver must be installed in the PC. For details on how to install, refer to the "USB Driver Installation Manual".

Use the cable with A-type and B-type connectors to connect the GLT400 to a PC.

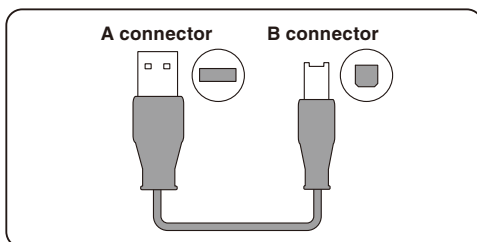

LAN Connection

Use a LAN cable to connect the GLT400 to a PC.

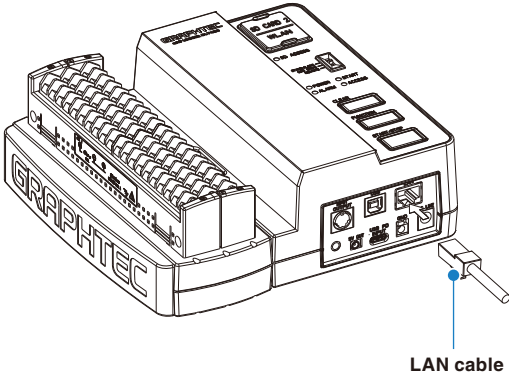

Cable Types

Use a crossing cable when connecting directly to a PC, without using a hub.

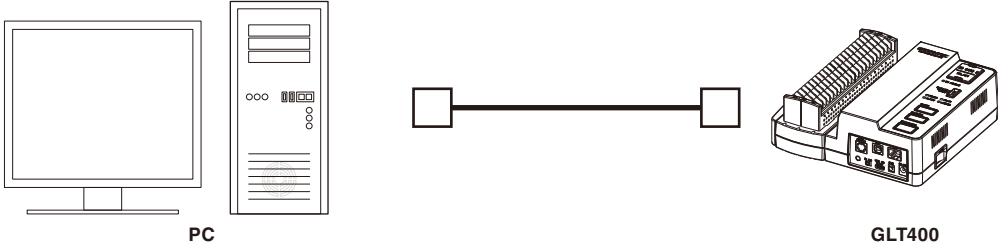

Use a straight cable when using a hub.

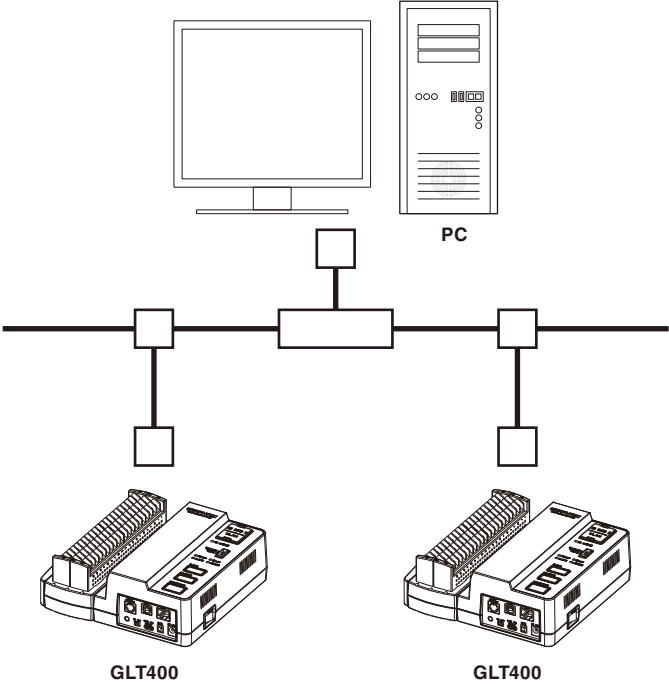

Connection to the wireless LAN

Insert the wireless LAN unit (option). For the insertion, refer to “2.13 Installing the Wireless LAN Unit (B-568: option)”.

(1) Connect to the wireless LAN base unit (sold separately)

The following devices and environment condition are required to connect to the wireless LAN base unit (sold separately) and control multiple GLT400s with the PC.

- PC that can connect to wireless LAN using the dedicated software
- Wireless LAN base unit (device equipped with Wi-Fi certified wireless LAN base unit function)
- Internet connection condition for connecting to the Internet (Internet provider contract, mobile carrier contract, etc.)
- Internet connection and E-mail sending and receiving environment (Internet provider E-mail, WEB mail, etc.)

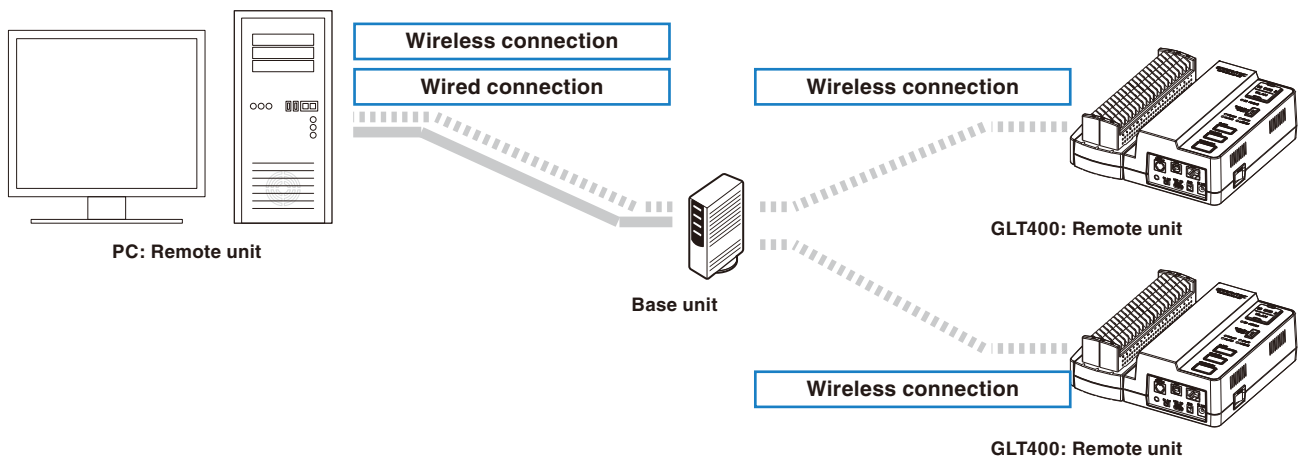

(2) Connect to the wireless LAN base unit of midi LOGGER GLT400

The midi LOGGER GLT400 as the wireless LAN base unit and the GLT400 as the wireless LAN remote unit can be connected.

When connecting the GLT400 as the remote unit, the Mode switch must be switched to REMOTE mode.



2.15 Connecting the Humidity Sensor (option)

Connect the + and - lead wires of the humidity sensor (the B-530: option) to the terminal to be used, and then insert the round connector into the 5V OUT connector on the GLT400.

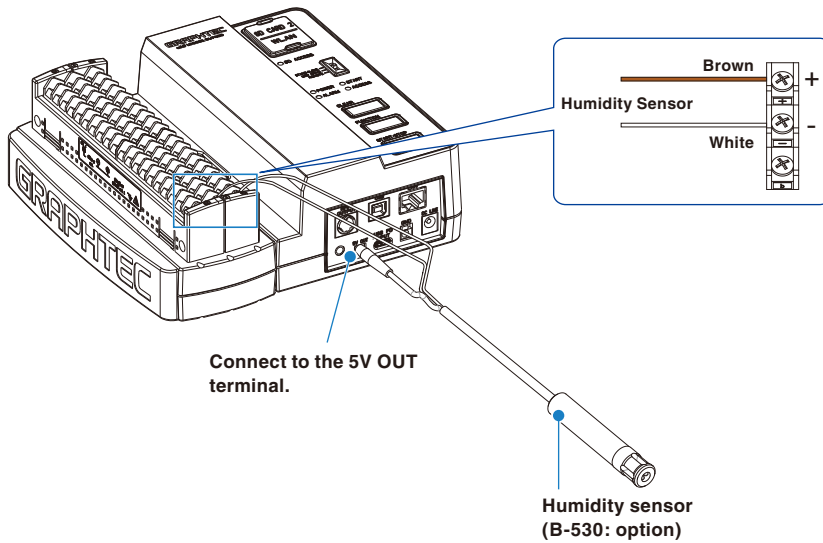

CAUTION

- Do not use the sensor in a strong electrolyte environment. Measurement results may not meet the specifications.
- The optional humidity sensor power BOX (B-542) is required to use 2 to 10 humidity sensors.
- 5V OUT terminal on the GLT400 is available for only one humidity sensor.

2.16 Precautions to Observe When Performing Measurement

WARNING

- Do not apply radio-frequency signals with high voltage (50 KHz or above).
- For the AC adapter, always use the supplied adapter or the recommended adapter. The rated power of the AC adapter is 100 to 240 VAC, and the rated power frequency is 50/60 Hz. Do not use it at any other voltage.
The operating environment in which B-564 (or B-564SL) and B-565 are mixed is 0 to 45°C.
- Do not input the voltage that is exceeding the specification of this device.
 - If a voltage exceeding the specified value is input, the semiconductor relay in the input section will be damaged. Never input a voltage exceeding the specified value even for a moment. It will cause the fire.
 - Have an enough margin from the specification of withstanding voltage when using this device, it have to consider a noise and change of the measurement voltage.
 - Confirm this device is not broken before the input cable is connected to the input terminal.
 - Please take care of the static electricity when the connecting the input cables or the thermocouples.
 - Do not touch the tip of thermocouples with bare hand after the thermocouples are connected to the terminal of this device when the tip of thermocouples is not insulated.
The static electricity of a human body will cause damage to this device.
 - Do not put the tip of thermocouples to the object which is containing the static electricity when the tip of thermocouples is not insulated. The static electricity of object will cause damage to this device.
 - Do not put the tip of thermocouples to the object which is containing the leaked high voltage of chassis or metal etc. when the tip of thermocouples is not insulated.
The leaked high voltage of object will cause damage to this device.
 - We recommend that the insulation tape puts on the tip of thermocouples before connecting the thermocouples to the input terminals.
This will protect this device from the static electricity and the leaked high voltage.
- * This applies to all the channels even if channel extension is used.
- * When B-564 (or B-564SL) and B-565 are mixed, B-564 (or B-564SL) input specifications are applied to all channels.

B-564 (or B-564SL)

Please be sure to read the following carefully in order to prevent electric shocks or shorts.

● **Maximum input voltage**

If a voltage exceeding the specified value is input, the semiconductor relay in the input section will be damaged. Never input a voltage exceeding the specified value even for a moment.

* This applies to all the channels even if channel extension is used.

< Between +/- terminals (A) >

- Maximum input voltage : 60Vp-p (Range of 20mV to 2V)
- 110Vp-p (Range of 5V to 100V)

<Between input terminal/input terminal (B) >

- Maximum input voltage : 60Vp-p
- Withstand voltage : 350Vp-p/1 minute

<Between input terminal/GND (C) >

- Maximum input voltage : 60Vp-p
- Withstand voltage : 350Vp-p/1 minute

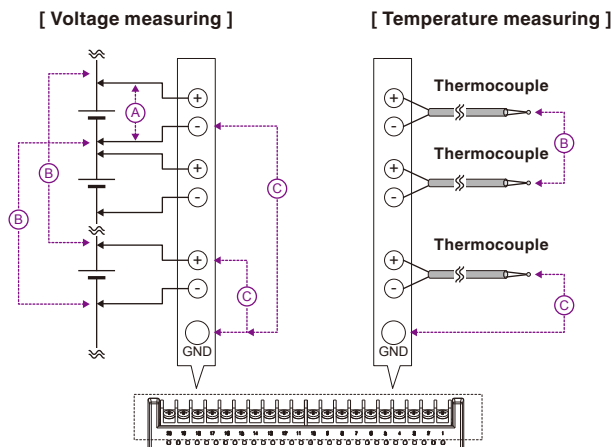

● **Input Circuit Diagram for Analog Input (Voltage, Thermocouples)**

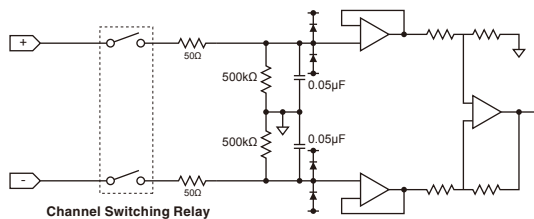

CAUTION

Capacitors have been incorporated into the input circuit to increase the noise elimination capability. After voltage measurement, when the inputs have been disconnected, there will still be some electric charge remaining.

Before starting another measurement operation, short-circuit the + and - terminals to enable self-discharge.

The GLT400 has a scan system.

While in the status (open) in which signals are not input to the input terminal, measured results may be influenced by signals from other channels. In such a case, turn OFF the input setting or short circuit +/-.

If signals are input correctly, measured results are not influenced by other channels.

B-565

● **Maximum input voltage**

If a voltage exceeding the specified value is input, the semiconductor relay in the input section will be damaged. Never input a voltage exceeding the specified value even for a moment.

* This applies to all the channels even if channel extension is used.

< Between +/- terminals (A) >

- Maximum input voltage : 60Vp-p (Range of 20mV to 2V)
- : 110Vp-p (Range of 5V to 100V)

<Between input terminal/input terminal (B) >

- Maximum input voltage : 600Vp-p
- Withstand voltage : 600Vp-p

<Between input terminal/GND (C) >

- Maximum input voltage : 300Vp-p
- Withstand voltage : 2300VACrms at 1 minute

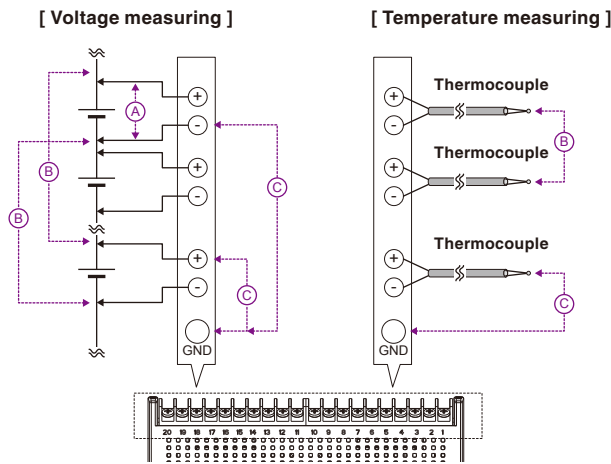

● **Input Circuit Diagram for Analog Input (Voltage, Thermocouples)**

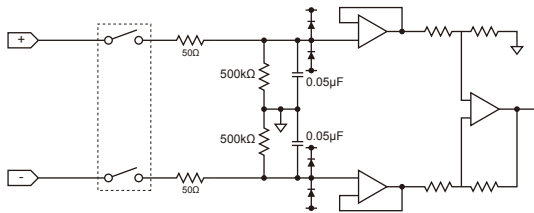

CAUTION

Capacitors have been incorporated into the input circuit to increase the noise elimination capability. After voltage measurement, when the inputs have been disconnected, there will still be some electric charge remaining.

Before starting another measurement operation, short-circuit the + and - terminals to enable self-discharge.

The GLT400 has a scan system.

While in the status (open) in which signals are not input to the input terminal, measured results may be influenced by signals from other channels. In such a case, turn OFF the input setting or short circuit +/-.

If signals are input correctly, measured results are not influenced by other channels.

2.17 Noise Countermeasures

● Be sure to connect the chassis GND of the measurement object.

It may become effective by ensuring that the chassis GND wire of the measurement object is connected to a good ground.

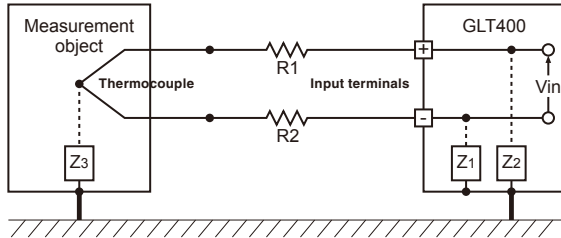

● Connect the signal chassis GND to the measurement device chassis ground.

Use a short, thick lead to connect the chassis GND of the measurement object to the GLT400's chassis GND. It will become even more effective if the ground potentials are the same.

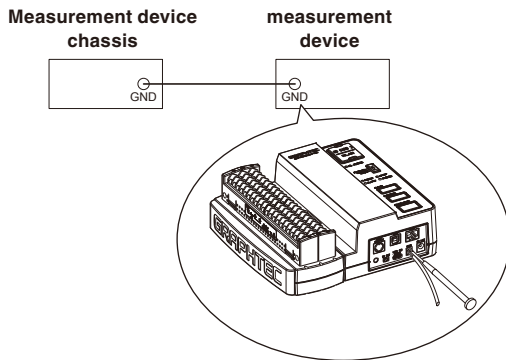

● Noise countermeasures

If measured values fluctuate due to extraneous noise, conduct the following countermeasures. (Results may differ according to noise type.)

Ex 1: Connect the GLT400's GND to ground.

Ex 2: Connect GLT400's GND to measurement object's GND.

Ex 3: In the AMP settings menu, set filter to any setting other than "OFF".

Ex 4: Set the sampling interval which enables GLT400's digital filter.

Use the "OTHER" menu to set the commercial power frequency you use.

For details, refer to "4.3 Settings screen" section.

2.18 When Fixing the GLT400 Body

Fixing the GLT400 body

To install vertically or attach to a DIN rail jig, etc., use the two nuts on the back of the GLT400.

Also, install the expansion terminal base connected to the GLT400 to a DIN rail jig, etc. using two nuts.

* Recommended tightening torque: 14 kgf/cm

When fixing the GLT400, it must be installed in horizontal state rather than in vertical or inclined state.

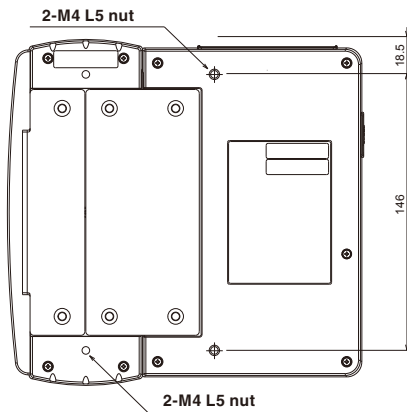

CAUTION

To prevent possible malfunction, do not block the air vents of the GLT400.

If the GLT400 is installed in other than the state described above, the measurement accuracy may not meet the specifications.

CHAPTER 3 Operation and Function

This chapter describes the operations and the main functions for the GLT400.

PRODUCT SUMMARY

- 3.1 Mode Switch Operation***
- 3.2 Key Operation***
- 3.3 Operation of LED***
- 3.4 Buzzer***
- 3.5 Description of Operation Mode***
- 3.6 WEB Server Function***
- 3.7 Other Functions***

3.1 Mode Switch Operation

This section describes the operation of the Mode switch.

The Mode switch is used to switch to one of three modes: STAND-ALONE, USB DRIVE, REMOTE. Switch the Mode switch when the power of the GLT400 is Off. The mode is not switched even if the Mode switch is switched when the power of the GLT400 is On. You need to perform the power cycle.

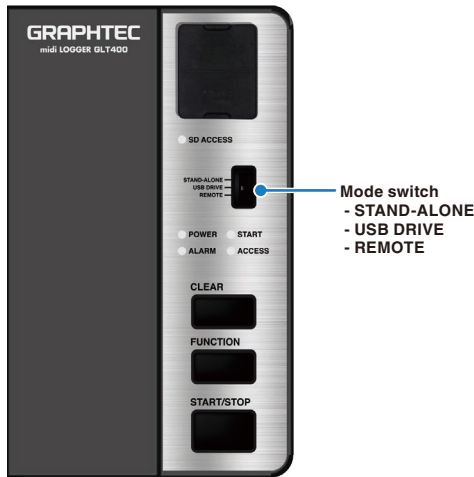

Mode switch
- STAND-ALONE
- USB DRIVE
- REMOTE

(1) STAND-ALONE



When using this GLT400 as a single recorder, set to "STAND-ALONE". You can control capturing with the GLT400 alone or PC software.

(2) USB DRIVE



Set to "USB DRIVE" when accessing the internal memory and SD CARD from the PC as external drive.

(3) REMOTE



Set to "REMOTE" when connecting the GLT400 as a remote unit of GL840. To connect as a remote unit, you need to connect between the GLT400 and the GL840 with the following method.

Wired LAN

Wireless LAN (B-568 (option) required)

Up to 5 GLT400s can be connected as a remote unit of GL840. When 5 GLT400s are connected to the GL840, up to 200 channels of analog input are possible.

Example: GL840 (20ch), GLT400-1 (100ch), GLT400-2 (40ch), GLT400-3 (20ch), GLT400-4 (20ch)

(4) Functions in each mode

The main functions of each mode are listed in the table below.

Functions	STAND-ALONE	USB DRIVE	REMOTE
Capture with the GLT400 alone	✓	–	–
Connect as a remote unit of GL840	–	–	✓
Setting and capturing control from PC software	✓	–	✓ Interface setting only are possible.
Transfer files in the GLT400 to PC	✓ Use PC software	✓ Only when connected via USB	–
Analog input	Max. terminal bases: 10 units (Up to 200 channels)	–	Max. terminal bases: 9 units (Up to 180 channels)*1
Logic/pulse input	Up to 4 channels	–	None*2
Sampling interval	Fastest 10 ms/1ch	–	Fastest 10ms/1ch*3
External sampling	✓	–	None
Number of alarm outputs	4 ports	–	1 port Output port is fixed to 1 channel
External trigger	✓	–	None
Calculation between channels	✓	–	✓ When the sampling interval is faster than 500 ms, the GLT400 transfers to the GL840 at 500 ms interval.*4
WEB server	✓	–	–
FTP server	✓	–	–
FTP client (as a backup function)	✓	–	–
Save and load operation settings	✓	–	✓*5
Save and load network settings	✓	–	✓

*1: At least 1 unit is required for the GL840, so up to 9 units can be connected.

*2: Logic/pulse cannot be used when the GLT400 is used in REMOTE mode.

*3: When the sampling interval is set faster than 500 ms in REMOTE mode, the real-time waveform display, calculation between channels and trigger detection, etc. are delayed because the data of the GLT400 is sent all together to the GL840 at intervals of 500 ms.

*4: The digital display value when the sampling interval is set faster than 500 ms is the calculation result at the 500 ms interval. The captured data are the calculated value at the sampling interval.

*5: In REMOTE mode, the operation settings are performed from the GL840 base unit, so the settings of the GL840 are overwritten.

3.2 Key Operation

This section describes the operation of the keys.

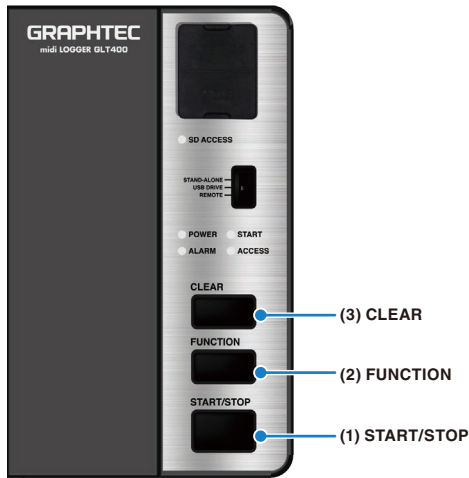

(1) START/STOP

The "START/STOP" key is activated by pressing and holding for 2 seconds.

When you press and hold the "START/STOP" key while capturing is stopped, capturing starts. When capturing starts, the input signal is saved in the specified medium (Internal memory or SD CARD).

When you press and hold the "START/STOP" key during capturing, capturing stops.

If the buzzer sound is enabled, the buzzer sounds when capturing starts and stops.

CAUTION

The START/STOP key is available in STAND-ALONE mode only.

(2) FUNCTION

Various functions are assigned to the "FUNCTION" key.

The operation differs depending on whether you press it at startup or during startup.

Operation at startup

When the mode switch is STAND-ALONE or REMOTE, if you turn on the power of the GLT400 while holding down the "FUNCTION" key, the network settings will be initialized.

* For the initialization settings, refer to “3.5 Description of Operation Mode (7) Initialize and read settings.

Operation during startup

The "FUNCTION" key is activated by pressing and holding it for 2 seconds.

The operation during startup depends on whether the capturing is in progress or stopped, or the medium inserted in the SD CARD slot.

Capturing status	SD CARD slot status	Description of function
When capturing is stopped (free running)	None or SD CARD is inserted	No function
	Wireless LAN unit (B-568) is connected	Wireless LAN Easy Connection (WPS)
During capturing	SD CARD is inserted	SD CARD is replaced

* For the capturing status, refer to “3.5 Description of Operation Mode (2) Capturing start and capturing stop operations”.

* For the connection of the wireless LAN unit (B-568), refer to “3.5 Description of Operation Mode (6) Wireless LAN Easy Connection (WPS)”.

* For the SD CARD replacement function, refer to “3.5 Description of Operation Mode (3) SD CARD replacement operation”.

(3) CLEAR

The "CLEAR" key is mainly used for the clear-related operations.

The operation differs depending on whether you press it at startup or during startup.

Operation at startup

When the mode switch is STAND-ALONE or REMOTE, if you turn on the power of the GLT400 while holding down the "CLEAR" key, the operation settings will be initialized.

* For the initialization settings, refer to “3.5 Description of Operation Mode (7) Initialize and read settings”.

Operation during startup

Clear each state. The content to be cleared depends on how you press the key.

How to press the key	Description of function
Single press	Clear error status (Clear the status where the POWER LED is lit in red)
Press and hold (2 seconds)	Alarm clear

* For the LED, refer to “3.3 Operation of LED”.

* For the alarm function, refer to “Chapter 4 Settings and Measurement (4) TRIG settings”.

* For details on the error, refer to “5.3 List of Error Codes.

3.3 Operation of LED

This section describes the operation of the LED.

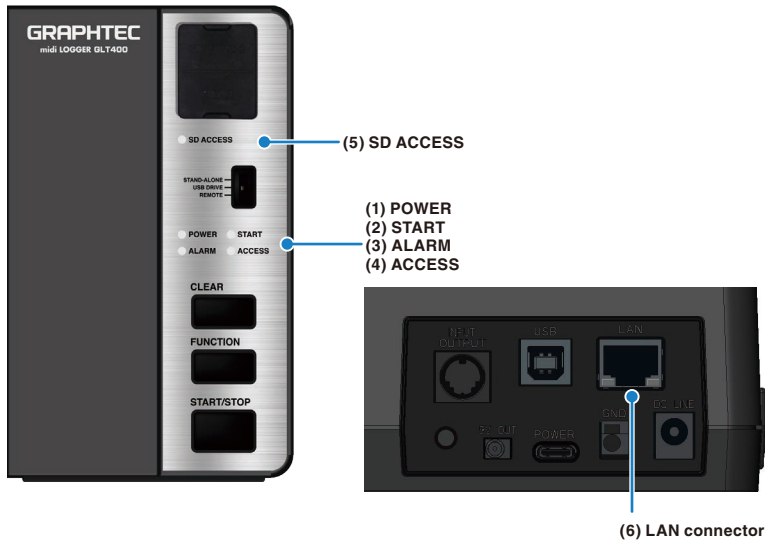

(1) POWER

This LED is lit in three colors: green, orange, and red. It mainly indicates the power supply status and error occurrence status.

Mode Switch status	Lighting status	Description
STAND-ALONE / REMOTE	Not lit	Power off status
	Lit in green	When started up
	Flashes in green	Starting up/Reading setting file
	Flashes in green	SD CARD can be replaced (During capturing)
	Flashes in orange	SD CARD replacement is in preparation
	Lit in red	Error occurred
USB DRIVE	Lit in orange	Operating in USB DRIVE mode

(2) START

This LED is lit in two colors: green and orange. It mainly indicates the capturing status

Mode Switch status	Lighting status	Description
STAND-ALONE / REMOTE	Not lit	Capturing stop (During free running)
	Lit in orange	Waiting for start trigger
	Lit in green	Capturing
	Flashes in orange	Capturing finished (Stop trigger is established), Waiting for repeat capturing
USB DRIVE	Always not lit	Not used

(3) ALARM

This LED is lit in one color: red. It is lit when an alarm is output.

* For the alarm function, refer to “Chapter 4 Settings and Measurement (4) TRIG settings”.

Mode Switch status	Lighting status	Description
STAND-ALONE / REMOTE	Not lit	Alarm has not been output
	Lit in red	Alarm has been output (During outputting alarm)
USB DRIVE	Always not lit	Not used

(4) ACCESS

This LED is lit in one color: green. It is lit when reading/writing from/to the internal memory.

Mode Switch status	Lighting status	Description
STAND-ALONE / REMOTE / USB DRIVE	Not lit	Not accessing (reading/writing) the internal memory
	Lit in green	Accessing (reading/writing) the internal memory

(5) SD ACCESS

This LED is lit in one color: green. The operation depends on the medium inserted in the SD CARD slot.

Mode Switch status	SD CARD slot status	Lighting status	Description
STAND-ALONE / REMOTE	Not inserted	Not lit	Always not lit
	SD CARD	Not lit	Not accessing (reading/writing) the SD CARD
		Lit in green	Accessing (reading/writing) the SD CARD
	Wireless LAN unit (B-568)	Not lit	Wireless LAN unit is not communicating
		Lit in green	Wireless LAN unit is communicating
		Flashes in green	IP Address Auto Acquisition (DHCP) is being performed during performing Easy Connection (WPS)
USB DRIVE		Always not lit	Not used

(6) LAN connector

This LED is lit in one color: green. It flashes when LAN communication is performing.

Mode Switch status	Lighting status	Description
STAND-ALONE / REMOTE	Not lit	LAN cable is not connected
	Lit in green	LAN cable is connected
	Flashes in green	When LAN communication starts
USB DRIVE	Always not lit	Not used

3.4 Buzzer

This section describes the buzzer operation. For the buzzer sound, refer to “3.5 Description of Operation Mode”.

The buzzer sound can be turned off in the settings. For the buzzer sound settings, refer to “Chapter 4 Settings and Measurement (6) OTHER Settings (6)-1 Buzzer”.

(1) Key click sound

The buzzer sounds immediately when the single press key is performed and sounds when the long press is performed and it is confirmed.

Status	Description
When clicking the key	Pi

(2) Start/stop capturing

These are buzzer sounds when capturing starts and stops.

Status	Description
Capturing started	Pi Pi Pi
Capturing stopped	Pi Pi Pi
Capturing start failed	Bi Bi - - -

(3) When an error occurs

This is a buzzer sound when an error or warning occurs.

Status	Description
Error occurred	Bi Bi - - -
Warning occurred	Pi Pi Pi Pi Pi Pi Pi Pi Pi

(4) Replacement of SD CARD

When the SD CARD is replaced during capturing, a buzzer sounds to notify you of the status.

Status	Description
When SD CARD is replaced	Pi (As a FUNCTION key sound)
When SD CARD replacement failed	Bi Bi - - -
SD CARD replacement is in standby	Pi - - - Pi - - - Pi - - -
SD CARD replacement completed	Pi Pi Pi
SD CARD replacement error occurred	Bi - - - (about 3 seconds) Pi Pi Pi

(5) Wireless LAN Easy Connection (WPS)

When the wireless LAN unit (B-568) (option) is installed on the GLT400 and capturing is stopped, press and hold the [FUNCTION] button to enter Wireless LAN Easy Connection mode, and a buzzer notifies you of the status.

Status	Description
Easy connection starts	Pi (As a FUNCTION key sound)
Easy connection failed	Bi Bi - - -
Easy connection in operation	No sound
Easy connection was successful	Pi Pi Pi
Easy connection error occurred	Bi Bi - - -

(6) Others

The buzzer notifies you of the status with the following buzzer sound.

Status	Description
When the firmware version upgrade is completed	Pi - - - (about 10 seconds)
Initialization of operation settings started at startup	Pi Pi
Network settings started at startup	Pi Pi
Reading of the operation setting file started at startup	Pi
The operation setting file was successfully read at startup	Pi Pi Pi
Reading of the operation setting file failed at startup	Bi Bi - - -
Network setting file reading starts at startup	Pi
Network setting file was successfully read at startup	Pi Pi Pi
Network setting file reading failed at startup	Bi Bi - - -

3.5 Description of Operation Mode

(1) Operation at startup

STAND-ALONE/REMOTE mode

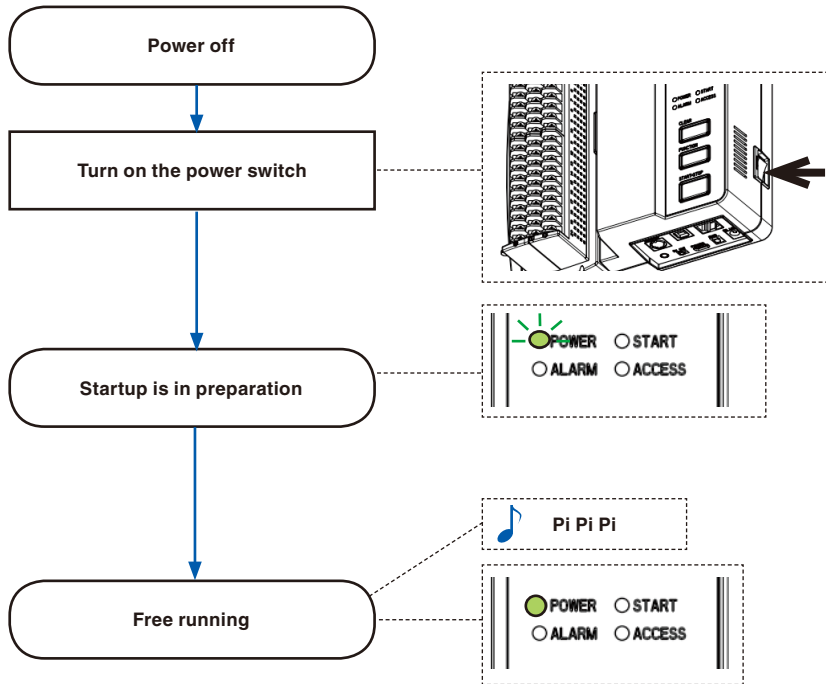

<Automatic reading of operation setting file and network setting file>

Save the automatic reading operation setting file "AUTOSET.CND" and the automatic reading network setting file "AUTOSET.NCD" in the root folder of the SD CARD of the GLT400 in advance. The operation setting file can be created with the GLT400 Setting App.

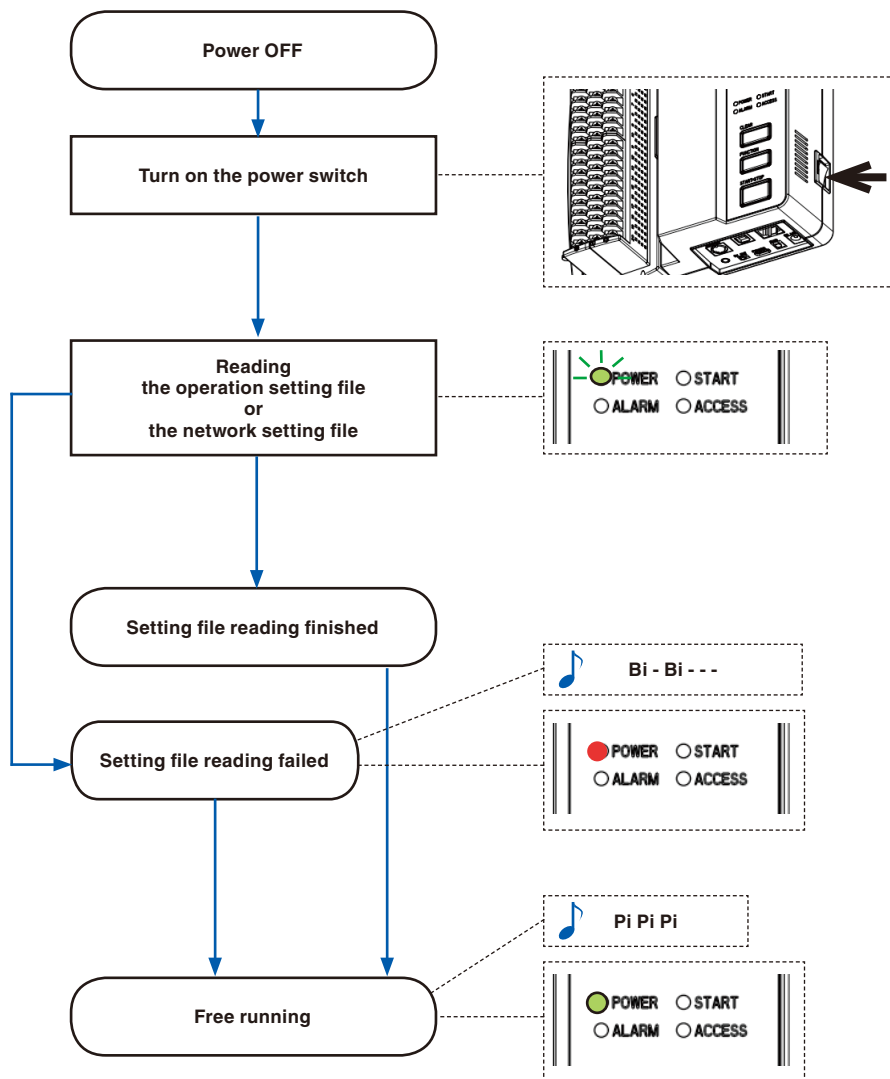

CHECKPOINT

AUTOSET.CND and AUTOSET.NCD files are identified by the file name. Therefore, you can create an automatic reading file name by changing to the same name.

If both AUTOSET.CND and AUTOSET.NCD files are saved in the SD CARD, both files are read.

<Initialization of operation settings and network settings>

The contents of the operation settings and network settings are initialized at startup.

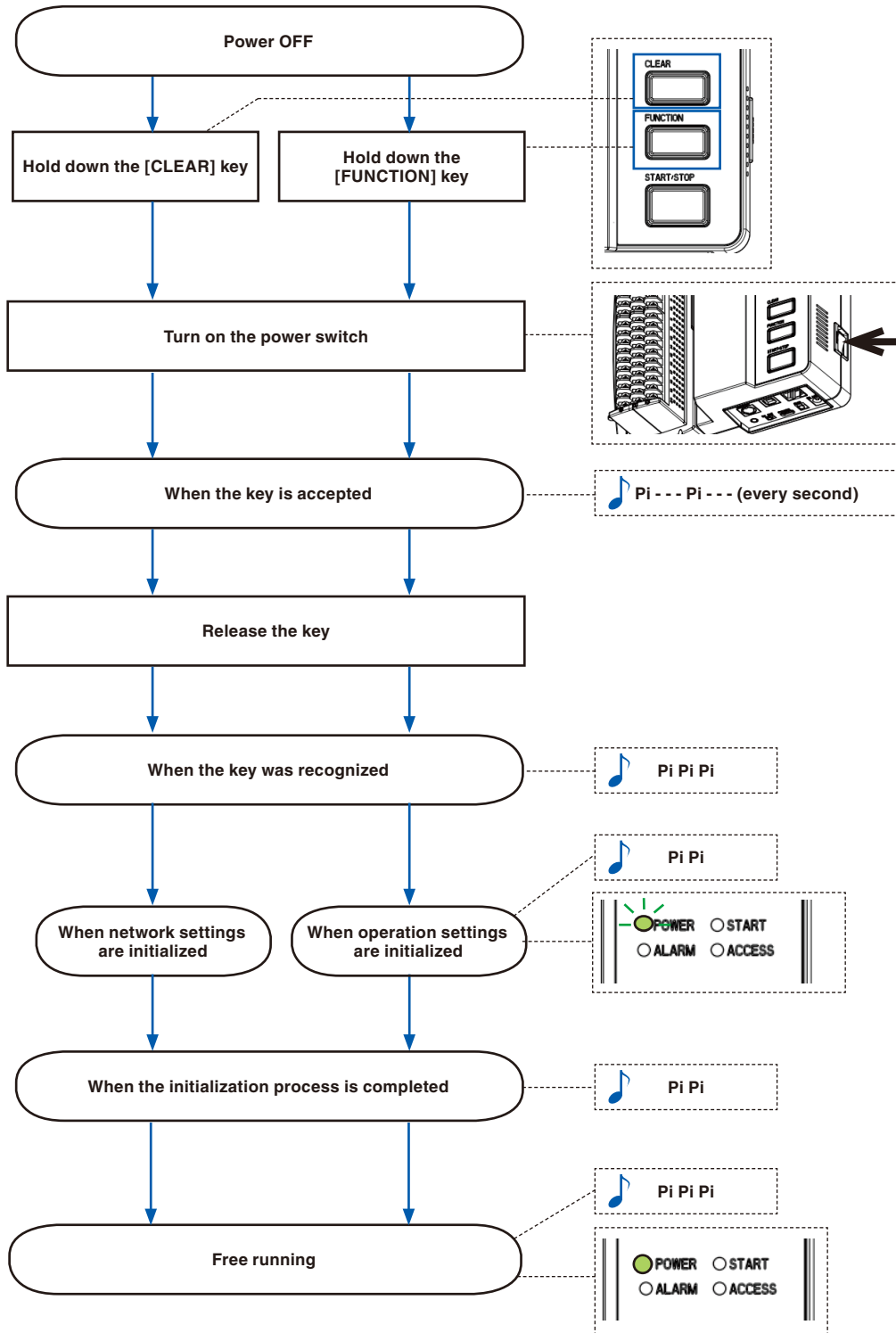

* For details on the initialization of settings, refer to “(7) Initialize and read settings”.

USB DRIVE

Connect between the GLT400 and PC with a USB cable in advance.
 When the USB drive mode is entered, the internal memory and SD CARD (when the wireless LAN unit is not installed) are displayed on the Explorer as USB drive on the PC.

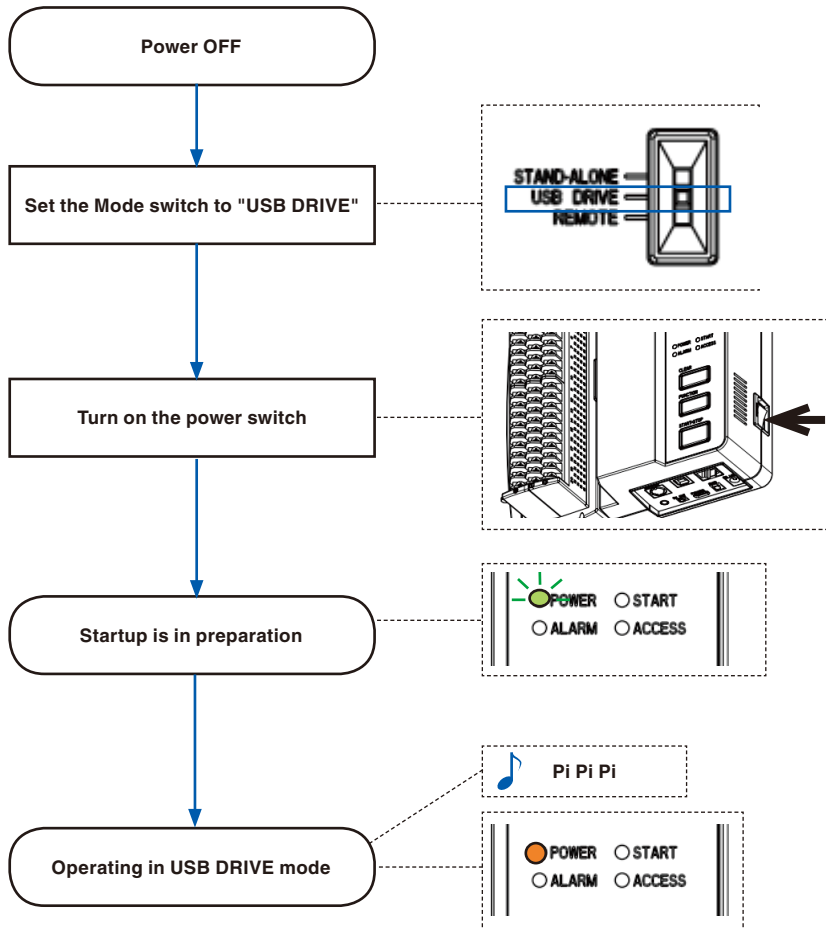

(2) Capturing start and stop operations

In STAND-ALONE mode, you can control the capturing start and stop of the GLT400 by pressing the START/STOP key of the GLT400.

Set the capturing settings in advance using the supplied GLT400 Setting App software. For the GLT400 Setting App, refer to “Chapter 4 Settings and Measurement”.

When controlling the capturing from the control software GL-Connection, refer to the GL-Connection User’s Manual.

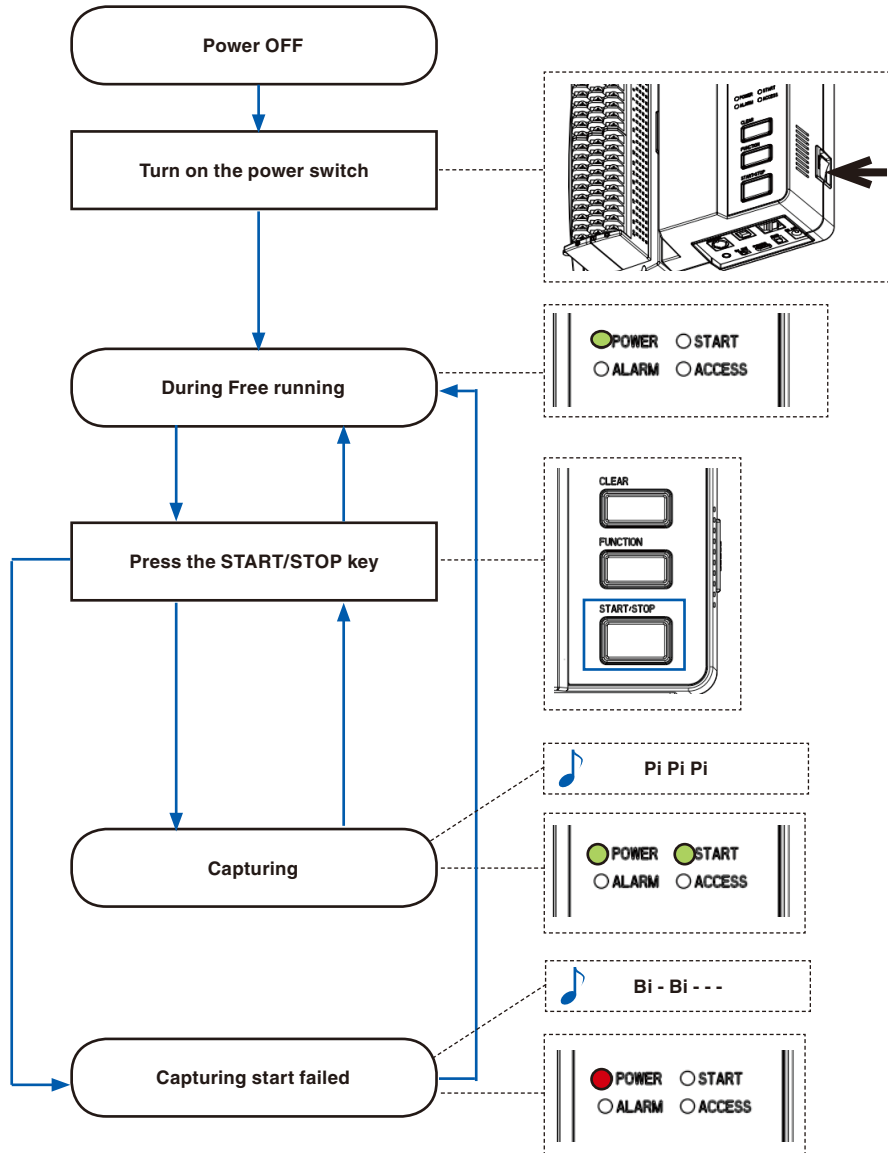

Operation	Description of operation
Free running	GLT400 is in the startup state or when it is not capturing.
Capturing	The data is captured

CAUTION

Capturing operation cannot be performed by the GLT400 alone in REMOTE mode.

Capturing operation cannot be performed in USB DRIVE mode.

CHECKPOINT 

When the Power On start function is enabled, the capturing status is entered directly from the time the power is turned on. For the Power On start, refer to “Chapter 4 Settings and Measurement (6) OTHER settings (6)-2 Power On start”.

Data can be acquired using the control software GL-Connection or interface commands even in the free running state.

(3) SD CARD replacement operation

The SD CARD can be replaced during capturing. The SD CARD replacement function must meet the following conditions.

Capturing destination	Backup destination	Other conditions	SD CARD replacement
Internal memory	None		Not applicable
	SD CARD		Replaceable (backup side)
		Ring capturing is enabled	Not available
		When external sampling is set	Not available
	Capturing format is CSV format	Not available	
FTP server		Not applicable	
SD CARD	None		Replaceable (capturing side)
		Ring capturing is enabled	Not available
		When external sampling is set	Not available
	Internal memory		Replaceable (capturing side)
		Capturing format is CSV format	Not available
	Ring capturing is enabled	Not available	
	When external sampling is set	Not available	
FTP server		Not available	

SD CARD replacement procedure

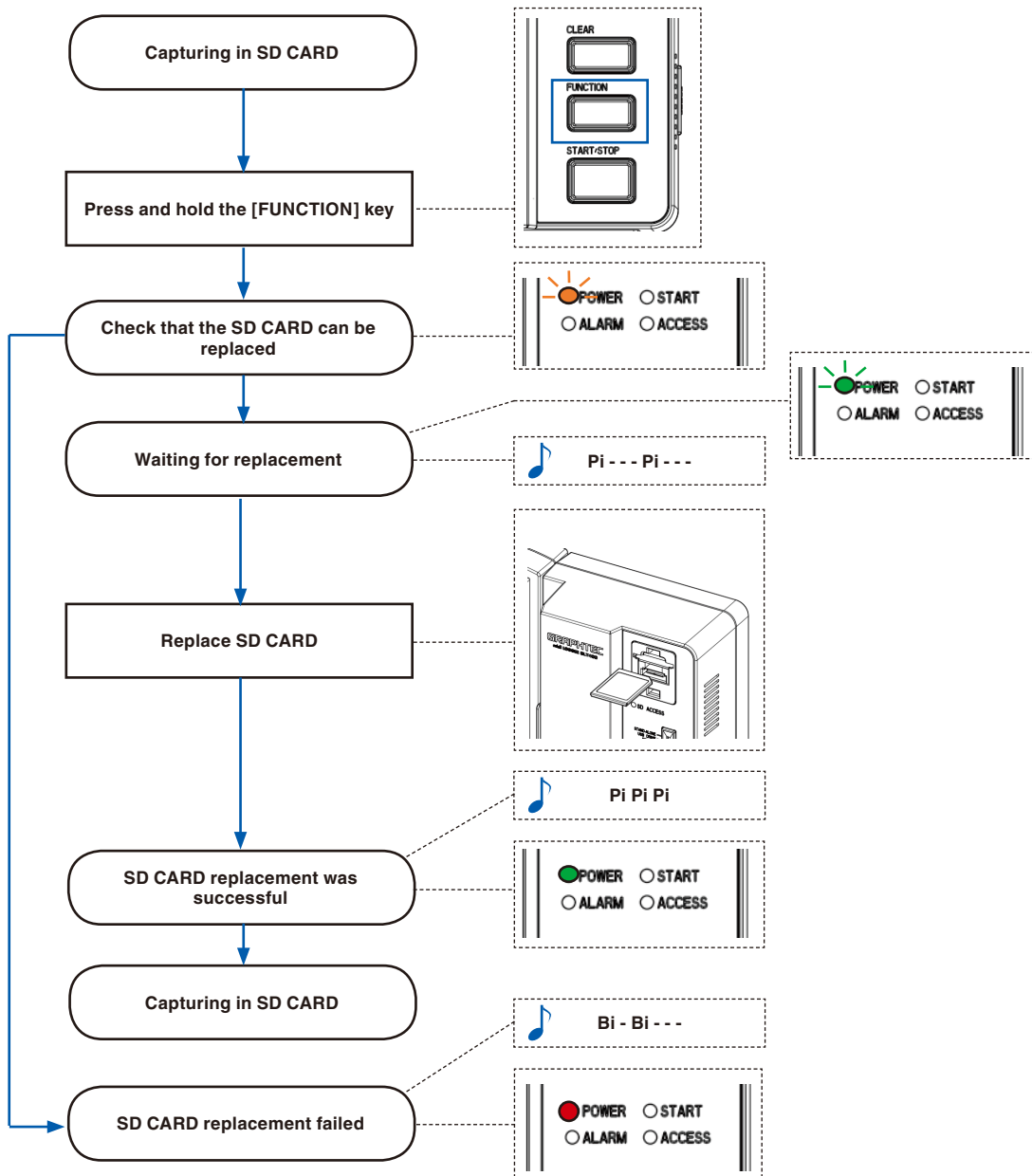

If an error occurs when replacing the SD CARD, the POWER LED is lit in red, so insert a writable SD CARD.

 **CAUTION**

SD CARD replacement must be completed within 10 minutes. If it takes more than 10 minutes to replace the SD CARD, data is lost.

CHECKPOINT 

Every time the SD CARD is replaced, the _CHG number is added to the file name.

Example: When capturing with the file name "TEST.GBD"

First SD CARD: TEST.GBD

Second SD CARD: TEST_CHG1.GBD

SD CARD cannot be replaced when ring capturing is enabled.

(4) Operation when an alarm is output

When an alarm is output, the ALARM LED is lit in red. An alarm signal is output from the alarm output terminal when the LED is lit. If the alarm setting is set to "Hold alarm", the alarm is cleared by pressing and holding the [CLEAR] key.

 **CAUTION**

SD CARD replacement must be completed within 10 minutes. If it takes more than 10 minutes to replace the SD CARD, data is lost.

5) Operation when an error occurs

If any error occurs while the GLT400 is operating, the POWER LED is lit in red and the buzzer sounds. You can check the error details from the GLT400 Setting App. Use the same software to clear the error. For details of the error, refer to "5.3 List of Error Codes".

 **CAUTION**

If the system goes down due to a hardware failure or firmware malfunction, the buzzer will sound continuously and the POWER LED and START LED flashes in red alternately.

In this case, you cannot get the error log with GLT400 SETTING APP.

If this happens, turn off the power switch and please contact us.

(6) Wireless LAN Easy Connection (WPS)

When the wireless LAN unit (B-568) (option) is connected, the wireless LAN can be easily connected by using the Wireless LAN Easy Connection (WPS) function.

* To use this function, the GLT400 must be in the Free running (capturing stopped) status.

STAND-ALONE mode

Connect the separately sold wireless LAN router (wireless LAN base unit) to the GLT400 (wireless LAN remote unit).

CHECKPOINT

Check in advance whether the wireless LAN router you will use has a function equivalent to WPS.

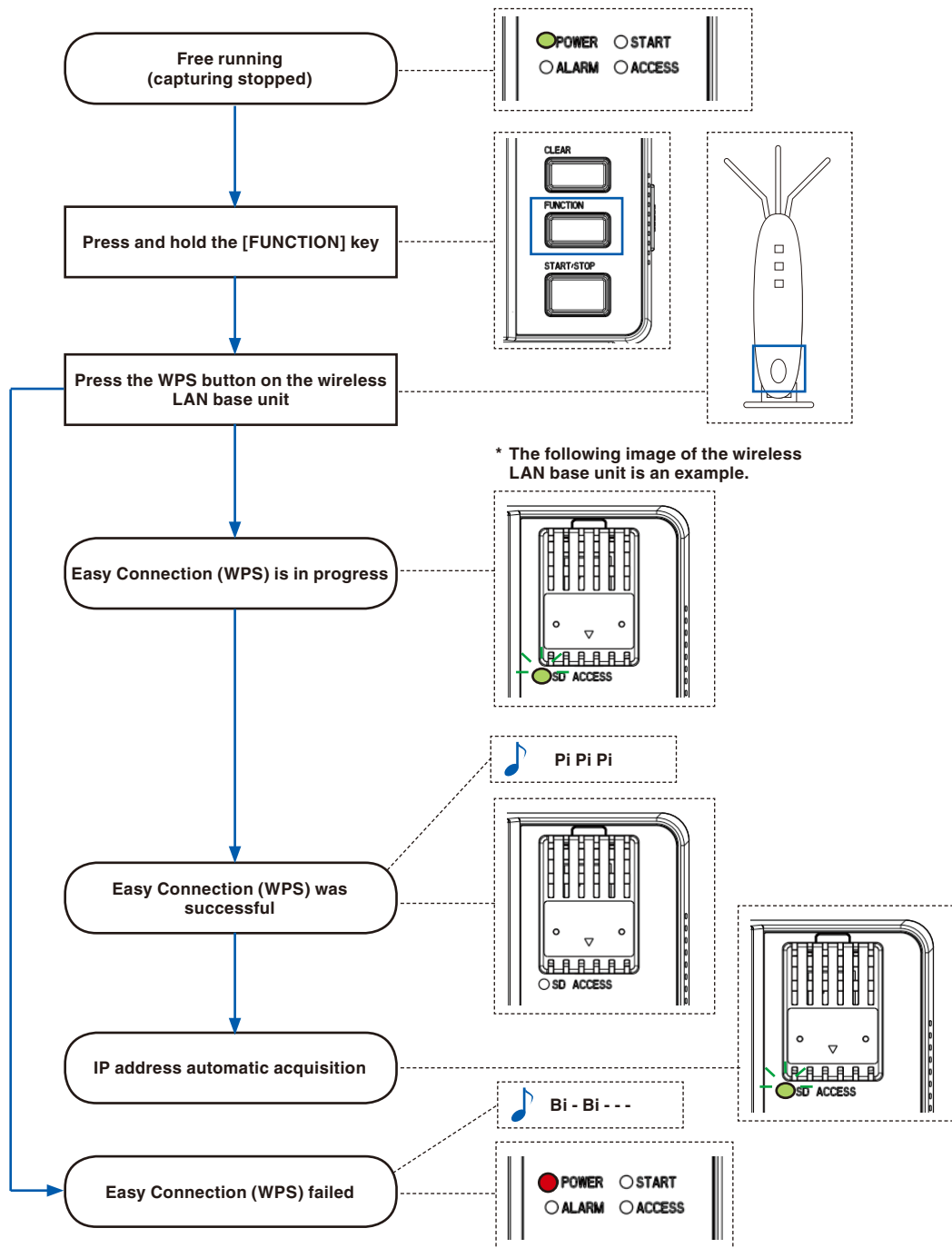

REMOTE mode

The GLT400 becomes the wireless LAN remote unit and the GL840 becomes the wireless LAN base unit.

* Please prepare the following for GL840 in advance.

- Connect wireless LAN unit B-568 (option)
- Access point mode setting
- Set Easy Setting (WPS) to Push button

If it is not completed properly, review the wireless environment such as communication distance and try again.

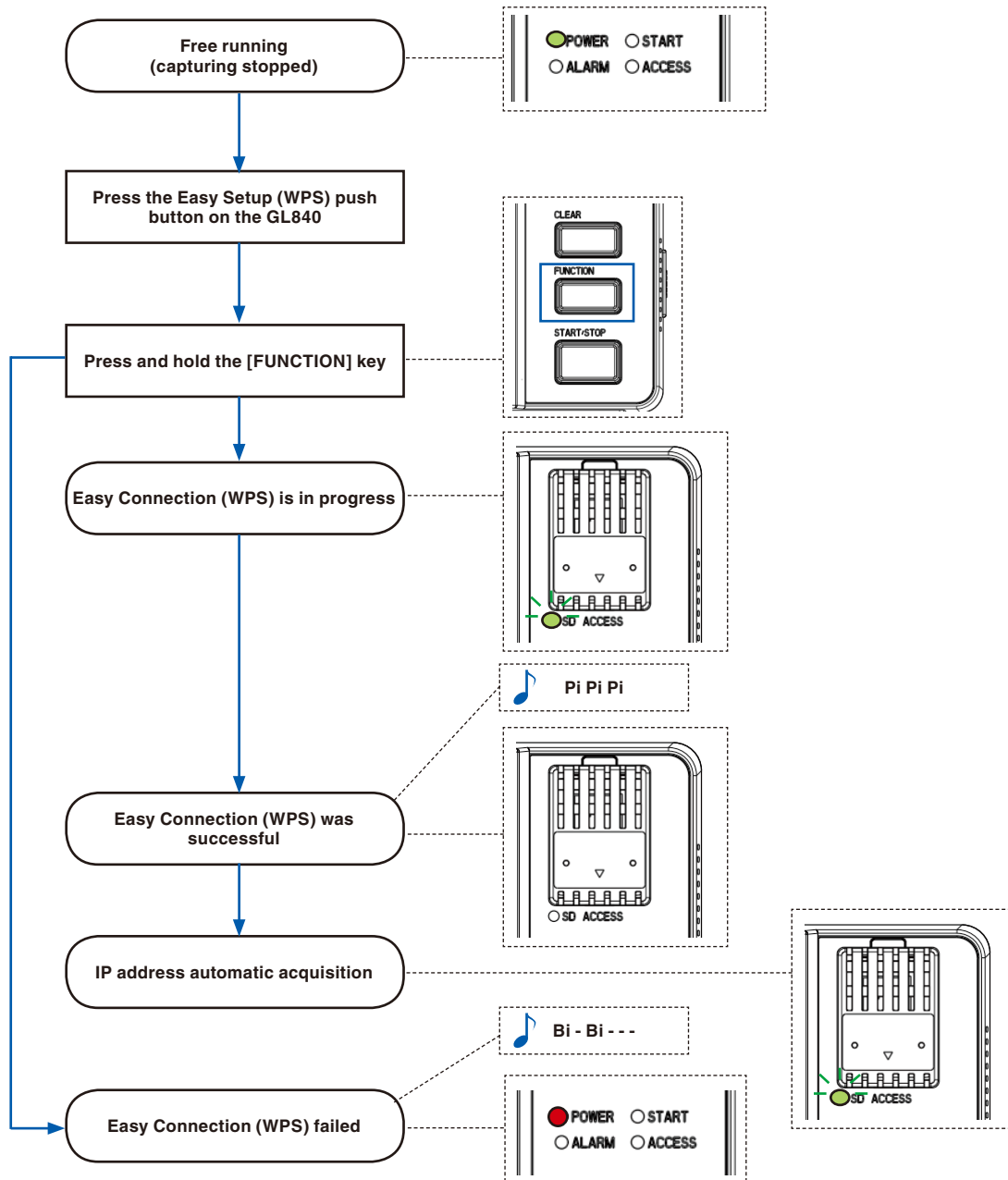

(7) Initialize and read settings

The following table shows the effects when initializing operation settings, initializing network settings and reading operation or network setting files.

Classification	Settings	Operation settings		Network settings	
		Initializing	Reading	Initializing	Reading
Settings for each analog channel	Input	✓	✓		
	Range	✓	✓		
	Temperature range	✓	✓		
	Temperature sensor	✓	✓		
	Span	✓	✓		
	EU (scaling)	✓	✓		
	Zero adjustment	✓	✓		
	Calculation between Channels	✓	✓		
	Annotation	✓	✓		
	Alarm level	✓	✓		
	Alarm output port	✓	✓		
	Trigger mode	✓	✓		
	Trigger level	✓	✓		
	Logic/pulse settings	Logic/pulse function	✓	✓	
Logic filter		✓	✓		
Logic alarm mode		✓	✓		
Logic alarm output port		✓	✓		
Logic trigger mode		✓	✓		
Pulse input		✓	✓		
Pulse slope		✓	✓		
Pulse filter		✓	✓		
Pulse EU (scaling)		✓	✓		
Number of pulses per revolution		✓	✓		
Pulse alarm		✓	✓		
Pulse alarm output port		✓	✓		
Pulse trigger		✓	✓		
Overall settings		Sampling interval	✓	✓	
	External sampling function	✓	✓		
	External sampling AC line filter	✓	✓		
	Capturing file format	✓			
	Capturing file name settings	✓			
	Ring capturing/relay capturing	✓	✓		
	Backup	✓	✓		
	Source settings of trigger start side	✓	✓		
	Hold alarm	✓	✓		
	Alarm is output due to burnout	✓	✓		
	Source settings of trigger stop side	✓	✓		
	Repeat capturing	✓	✓		
	Checksum	✓	✓		
	Room temperature compensation	✓	✓		
	Temperature unit	✓	✓		
	Burnout	✓	✓		
	AC line frequency		✓		

Classification	Settings	Operation settings		Network settings	
		Initializing	Reading	Initializing	Reading
Network-related settings	IP Address Auto Acquisition (DHCP)			✓	✓
	IP address			✓	✓
	Subnet mask			✓	✓
	Port Number			✓	✓
	Gateway			✓	✓
	DNS address			✓	✓
	Disconnect when GLT400 is not communicating			✓	✓
	Identification name			✓	✓
	New Line Code			✓	✓
	USB ID			✓	✓
	Network time			✓	✓
	FTP client			✓	✓
	FTP server			✓	✓
	WEB server			✓	✓
	Wireless LAN			✓	✓
	E-mail Send			✓	✓
	E-mail sending server			✓	✓

3.6 WEB Server Function

This function allows operating and monitoring GLT400 via a Web browser.

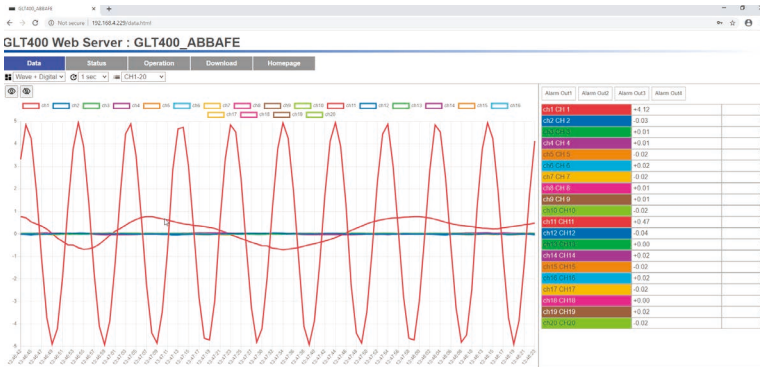

Supported Web browsers

- Google Chrome (Recommended)
- Microsoft Edge
- Firefox

* The web browser may not operate properly depending on the version upgrade. In that case, please try a different web browser.

Available functions using a Web browser

- Waveform and digital value display
- Operating status view
- Simple setting
- Linking to FTP (This function may not be available due to restrictions on the web browser.)
- Linking to our Web site

Setting the URL

The URL (Uniform Resource Locator) must be correctly set according to your network environment.

When the port number is changed, enter the following:

http://(IPAddress): Port number/

- http Protocol to access the server.
HTTP (Hyper Text Transfer Protocol)
- IP address Enter in the IP address to monitor.
- Port number Specify the port number.
The port number is the number set to the GLT400, or router, etc.



When the https is enabled in the WEB server settings, the URL is https://----- . In the standard setting, the server certificate is a self-signed certificate, and a warning may be displayed depending on the web browser, so please use it after understanding. If you want to install your own server certificate, please contact us.

The port number can be omitted. If omitted, it is 80 (443 when https is enabled).

http://(IPAddress): 80/index.htm/

It is not possible to make simultaneously WEB connection from multiple browsers. Please use a single browser for one GLT400.

<Procedure>

1. Open the Web browser.
2. Type in the URL (http://IP address/Index.html) in the address input field.
If the basic authentication is set to On, you need to enter the user name and password you set.
(Both user name and password is "GLT400" by default.)

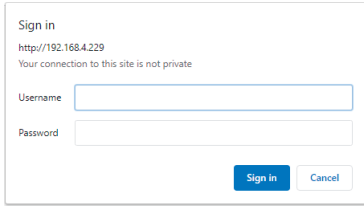

3. The following screen is displayed.

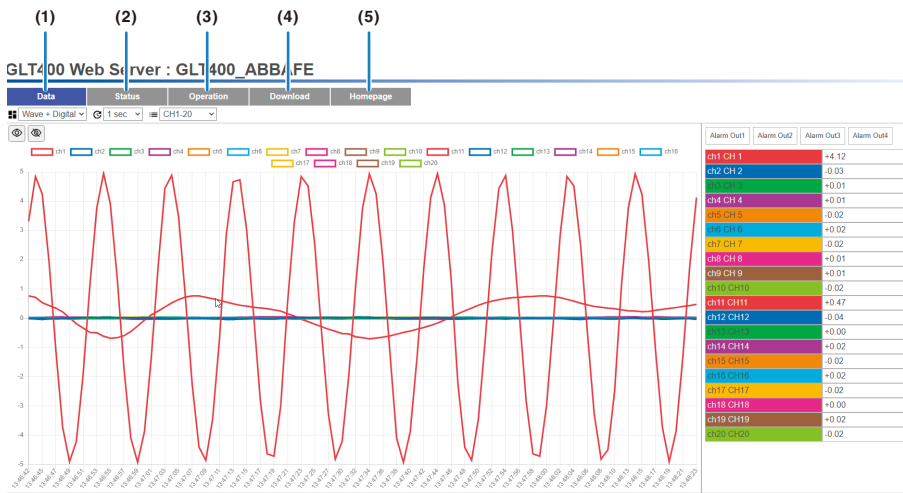

Selection Item	Description
(1) Data	Waveform display and digital display are possible.
(2) Status	The device name and capturing status can be checked.
(3) GLT400 operation	Capturing start/stop and simple control can be performed.
(4) Download	Using the FTP function, the data captured by the GLT400 can be downloaded to the PC. (This function may not be available due to restrictions on the web browser.)
(5) Home page	Link to our Home page.

Data

Three types of screens: waveform + digital display, waveform display and digital display can be displayed by switching the display mode.

CHECKPOINT

On this screen, the data after the time when the data screen is displayed is displayed. Therefore, past data can be not displayed.

The graph is displayed using the entire screen until the number of displayed points on the screen reaches 100. Therefore, the scale of the time axis changes accordingly./

When the number of displayed points on the screen reaches 100 or more, the data are scrolled and the data outside the screen are discarded.

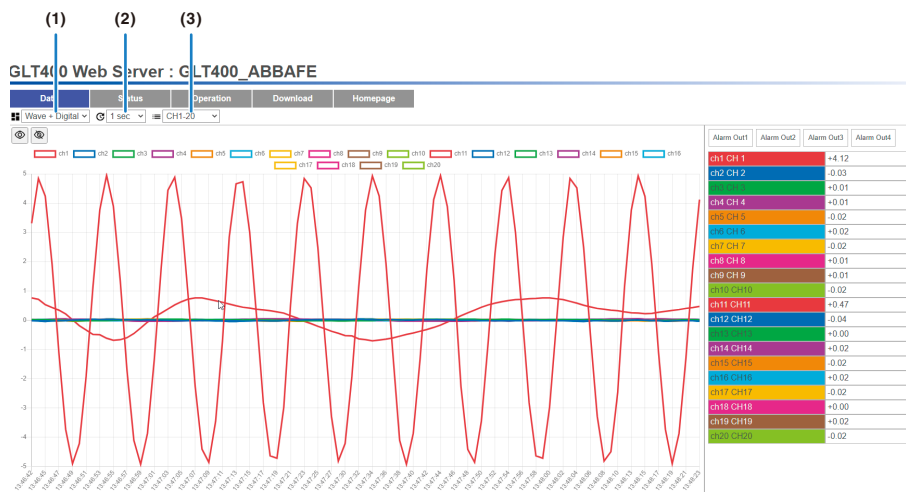

Selection Item	Description
(1) Display mode	Switch the display mode. Waveform + Digital: Waveform is displayed and it is displayed digitally at the same time. Waveform: Waveform is displayed. Digital: Displayed digitally.
(2) Update interval	Set the period for updating the waveform and digital displays. The data to be acquired depends on the sampling interval of the GLT400. The same data is acquired if the update interval is set faster than the sampling interval of the GLT400.
(3) Display channel	Select the channel to display on the screen. Select from AMP channel (for each 20CH), Logic, Pulse and Calculation between channels.

Waveform + digital display

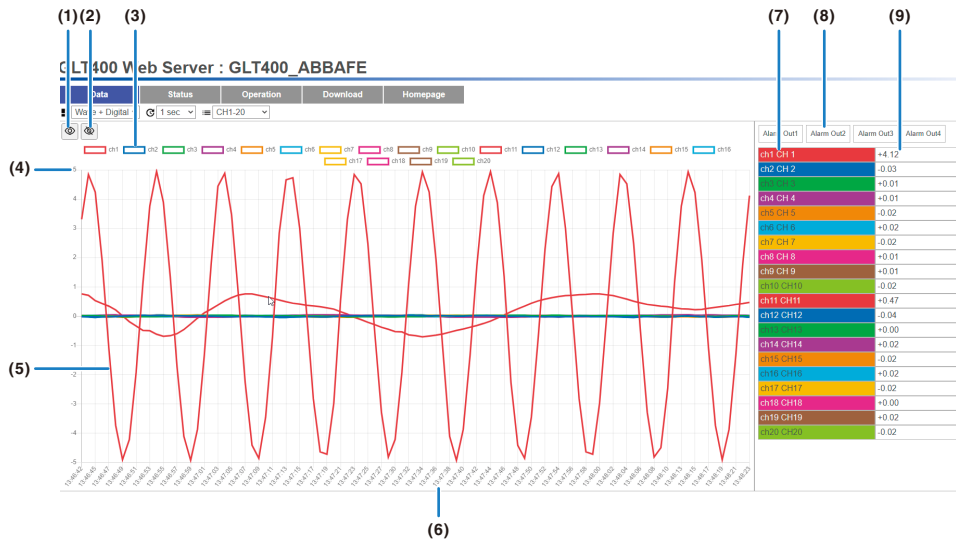

Selection Item	Description
(1) All channels display	Displays all waveforms of the channel selected in the display channel.
(2) All channels hide	Hides all waveforms of the channel selected in the display channel.
(3) Individual channel label (Switching between display and hide)	Switches between waveform display and hide for each channel.
(4) Level axis	Displays the level axis of the input signal. The level axis is automatically adjusted so that the maximum and minimum values of each channel are displayed within the graph.
(5) Waveform	Displays the waveform of the input signal. The temperature data burnout or out-of-range data waveforms are not displayed.
(6) Time axis	Displays the time when the signal was input. Even if the data interval is not constant due to external sampling etc., the waveform is displayed at equal intervals.
(7) Channel number and annotation	Displays the channel number and annotation string.
(8) Alarm output	Lights in red when an alarm is output.
(9) Digital values and unit	Displays digital values and unit strings. Lights in red when the channel alarm is output.

Waveform display

Refer to “Waveform + Digital display”

Digital display

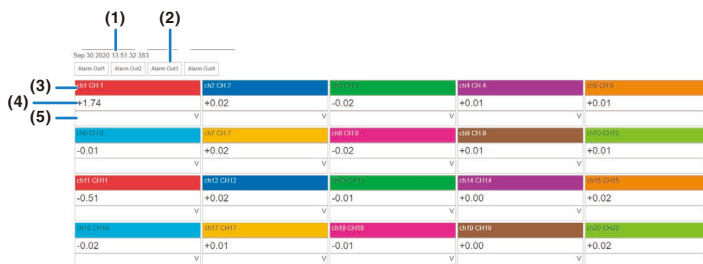

Selection Item	Description
(1) Time	Displays the time when the signal was input.
(2) Alarm output	Lights in red when the alarm is output.
(3) Channel number and annotation	Displays the channel number and annotation string.
(4) Digital value	Displays the digital values. Lights in red when the channel alarm is output.
(5) Unit	Displays the unit string.

Status

The device name and capturing status can be checked.

GLT400 Web Server : GLT400_ABBAFE

	Data	Status	Operation	Download	Homepage
(1)	Device name	GLT400_ABBAFE			
(2)	Recording status	Recording			
(3)	Start time	Sep 30 2020 13:52:05			
(4)	Trigger time	Sep 30 2020 13:52:05			
(5)	Recorded points	0			
(6)	Ch number	20 ch			
(7)	Sampling interval	200ms			
(8)	Recording file	MEM			
(9)	Capacity	3.9 GBytes			

Selection Item	Description
(1) Device name	Displays the device name. To change the device name, use the GLT400 Setting App on the PC.
(2) Capturing status	Displays the capturing status.
(3) Capturing start time	Displays the capturing start time. It is displayed only when capturing started.
(4) Trigger time	Displays the trigger time. It is displayed only when capturing started.
(5) Number of capturing points	Displays the number of capturing points. Refresh the screen on the web browser each time because it is not refreshed automatically.
(6) Number of channels	Displays the number of channels included in the GLT400.
(7) Sampling interval	Displays the sampling interval.
(8) Capturing file name	Displays the capturing file name or the folder name.
(9) Capturing capacity	Displays the capturing capacity.

GLT400 operation

Capturing start/stop and simple control can be performed.

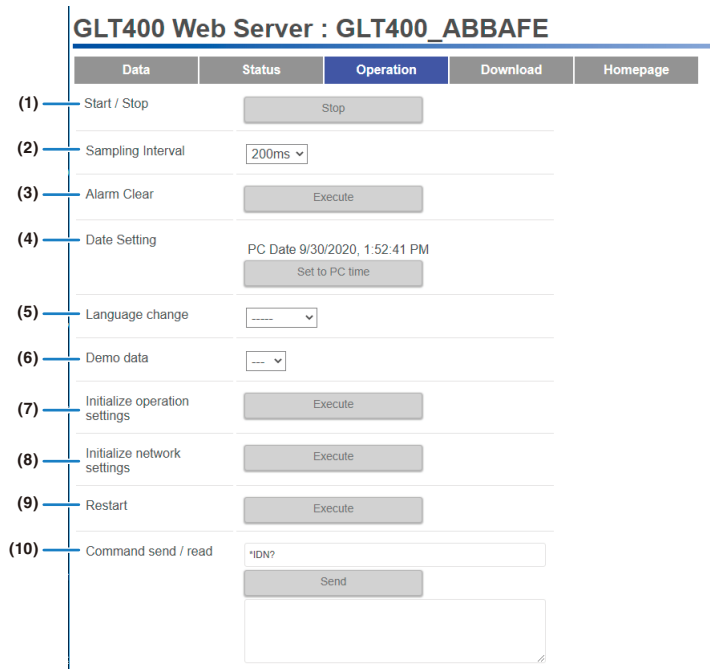

Selection Item	Description
(1) Start/Stop	Starts and stops capturing on the GLT400. It takes a few seconds for the status to be reflected.
(2) Sampling Interval	Changes the sampling interval. When set to the sampling interval that cannot be changed, it returns to the original set value after a few seconds.
(3) Alarm Clear	Performs alarm clear. It is available only when the alarm setting is set to "Hold alarm".
(4) Date Setting	Sets the clock of the GLT400. If the communication environment is poor, the set time may be shifted.
(5) Language change	Changes the language used in the GLT400 and the language displayed on the WEB server. When the language of the GLT400 is changed, it affects the language display of CSV data.
(6) Demo data	Enables demo data display. The demo data setting returns to Off when the power of the GLT400 is turned off and then on again.
(7) Initialize operation settings	Initializes the operation settings. The displayed contents after initialization may not match. In that case, reload the WEB screen.
(8) Initialize network settings	Initializes the network settings. If initialized, the network may be disconnected. Therefore, carry out with great care.
(9) Restart	Forcibly restart the GLT400. Perform this only when the condition of the GLT400 becomes unstable. The GLT400 is forcibly restarted, so carry out with great care.
(10) Command send/read	Sends and receives the interface commands of the GLT400. The GLT400 cannot send or receive the commands that process binary, such as receiving binary data. Be sure to send the commands separately for each command. The interface command specification is included in the SDK (Software Development Kit) of the GLT400. If you want to get the SDK, please contact us from our website.

Download

The files can be downloaded to the PC after confirming the information on the internal memory, SD CARD or FTP protocol in the GLT400.

* This function may not be activated due to the restrictions of the WEB browser. In that case, connect from the Explorer screen.

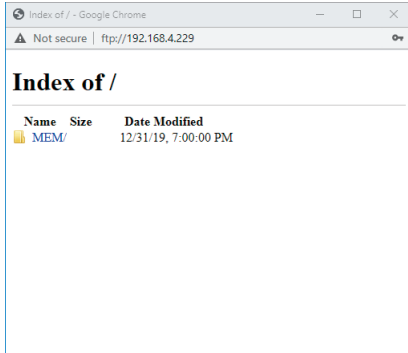

When the GLT400 is connected with the standard settings, you need to enter the user name and password. Both user name and password is "GLT400" by default.

To change to another user name and password, please use the GLT400 Setting App on the PC.

To download the file, right-click on the target file and select "Save as in link destination" to download it to the PC

<When connecting with Explorer>

To display the FTP site in Explorer, open the Explorer screen and enter the following in the path entry field. When the files within the GLT400 are displayed, you can perform normal file operations.

ftp://<user name>:<password>@<FTP server name>

<Setting example>

FTP server name: 192.168.0.1

User name: GLT400

Password: abced

URL: ftp://GLT400:abcde@192.168.0.1

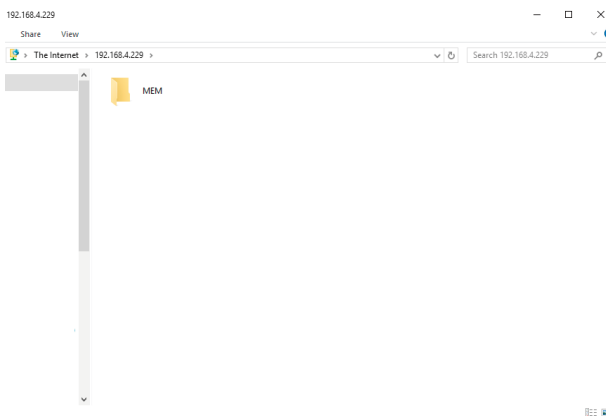

When the FTP server encryption method is set to "On" (other than Off) (FTPS), you cannot connect from a WEB browser or Explorer. Please use the Download App software included with GL-Connection or commonly used FTP client software.

3.7 Other Functions

The GLT400 has various functions other than those described above.

Data collection and control of the GLT400 by our dedicated program

The API (Application Program Interface) of the GLT400 that acquires and controls data is open to the public. Using this API, it is possible to perform our own controls that cannot be handled by the GLT400 or standard software applications.

For API control, the sample programs are provided in the SDK (Software Development Kit).

You can create a program relatively easily using these sample programs. If you want to get the SDK, please contact us from our website.

Supported protocol

Our own API command

Modbus/TCP

Main sample program languages

Visual C++

Visual Basic

.NET Framework C#

National Instruments LabVIEW

CHAPTER 4 Settings and Measurement

This chapter describes the settings of the GLT400 with the supplied GLT400 SETTING APP software.

PRODUCT SUMMARY

- 4.1 Overview of GLT400 SETTING APP***
- 4.2 Description of Screen***
- 4.3 Settings screen***
- 4.4 File Operations Screen***
- 4.5 Monitor Screen***
- 4.6 Save / Load Current Settings Screen***

4.1 Overview of GLT400 SETTING APP

(1) Overview

This software is a desktop application software for Windows OS that can be connected to the GLT400 via various interfaces to view or change settings, download captured files, and monitor digital values.

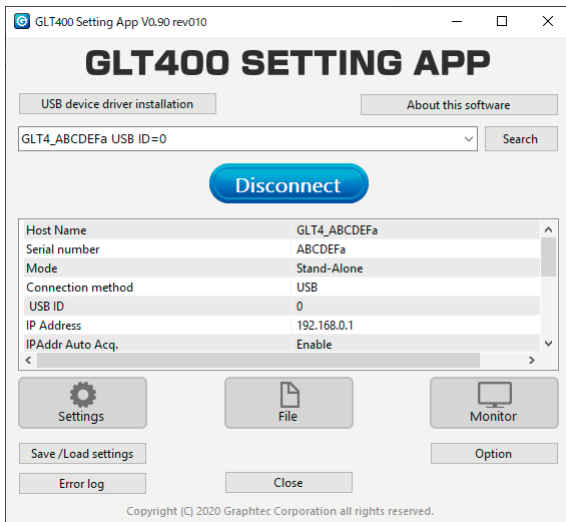

(2) Operating environment

The PC that you use should meet the following environment.

Tem	Required environment
OS	Windows 11 (64bit) Windows 10 (32Bit/64Bit) Windows 8.1 (32Bit/64Bit) * Meet system requirements of the OS. * We cannot support OS that is no longer supported by the OS manufacturer. * .NET Framework 4.6.1 or higher is required.
CPU	Intel Core 2 Duo or higher recommended * Please use a PC that meets the system requirements.
Memory	4GB or more recommended
HDD	4GB or more free space recommended
Display	Display resolution 1024 × 768 or higher and 65535 colors or higher (16 bits or higher) are required.
Network	USB 2.0 port (required) Ethernet interface * The USB port is required for the initial setting.

CAUTION

If the language of the application software and the language of the instrument do not match, you may not be able to correctly make the settings. Match the language of the instrument and the application.

(3) Software installation

This software is stored in the internal memory of the GLT400 in advance. After copying it to the PC in USB drive mode, it can be installed. Also this software can be downloaded from our website.

<Installation in USB drive mode>

- (1) Set the mode switch to "USB DRIVE" when the power of the GLT400 is off.



- (2) Connect between the GLT400 and PC with a USB cable (A-B type cable).
- (3) Turn on the power of the GLT400.
- (4) The internal memory of the GLT400 is displayed as the "USB drive" on the PC.

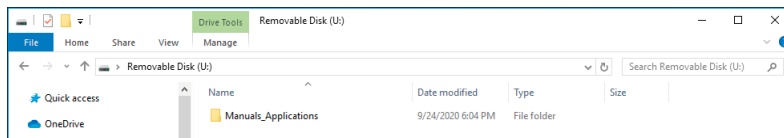

- (5) Copy the Manuals_Applications folder to the PC.
- (6) Execute Manuals_Applications → GLT400SettingApp → Setup.exe in the copied folder.
- (7) After that, follow the installer's instructions to install.

CHECKPOINT

The control software GL-Connection is also included in the Manuals_Applications folder. If you want to use the GL-Connection, install it as well.

If the Manuals_Applications folder in the GLT400 is not necessary, you can delete it.

When this software is installed on the PC in which the Microsoft .NET Framework 4.6.1 is not installed, the online installer of .NET Framework 4.6.1 starts when the installer starts. Follow the installer's instructions to install. When not connected to the network, execute dotnetfx46_full_x86_x64.exe in the copied Manuals_Applications folder to install.

<Download and install from our website>

Download "GLT400 Setting App" from "Measuring Instrument"-> "Data logger" at the following URL.

http://www.graphtec.co.jp/site_download/index.html

Unzip the downloaded file, start it and follow the installer's instructions to install.

(4) Basic functions

(1) View and change the settings

Connect to GLT400 to change and view the settings.

When the GLT400 is capturing, you can only view the settings.

The items that can be set differ depending on whether the GLT400 is STAND-ALONE mode or REMOTE mode.

- STAND-ALONE mode: All settings can be set and viewed.
- REMOTE mode: Network settings only can be set and viewed.

(2) File handling

The files in the internal memory and the SD CARD in the GLT40 can be viewed and downloaded.

* It is available in STAND-ALONE mode only.

(3) Monitor

The digital display and the capturing start and stop of the GLT400 can be controlled.

* It is available in STAND-ALONE mode only.

(4) Save/load settings

Operation settings and network settings can be saved in the GLT400's internal memory or SD CARD.

In addition, you can restore the settings by loading the saved file.

(5) USB driver installation

The USB driver must be installed to connect the GLT400 to the PC with the USB.

* To connect via the USB, you need to install the USB driver before that.

(6) Option

The display language and the decimal-point character can be changed and the GLT400 firmware can be updated.

(5) Start of software

After installing this software, select "Start Button" → "Graphtec" → "GLT400 Setting App" on the task bar of the screen to start the software.

When you start the software for the first time, the language selection screen is displayed.

Change to the desired language.

(6) Exit of software

To exit the software, press the "Close" button at the bottom of the main screen.

You can also close it from the [x] button described below.

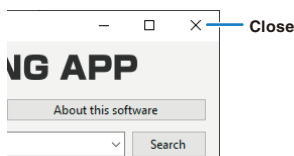

CHECKPOINT

The setting information entered last when the software is closed is retained. If you exit this application (When forcibly exited, etc.) other than the above, it is not retained.

4.2 Description of Screen

(1) GLT400 SETTING APP (Connect) screen

In this software, each function is accessed from the GLT400 SETTING APP (Connect) screen.

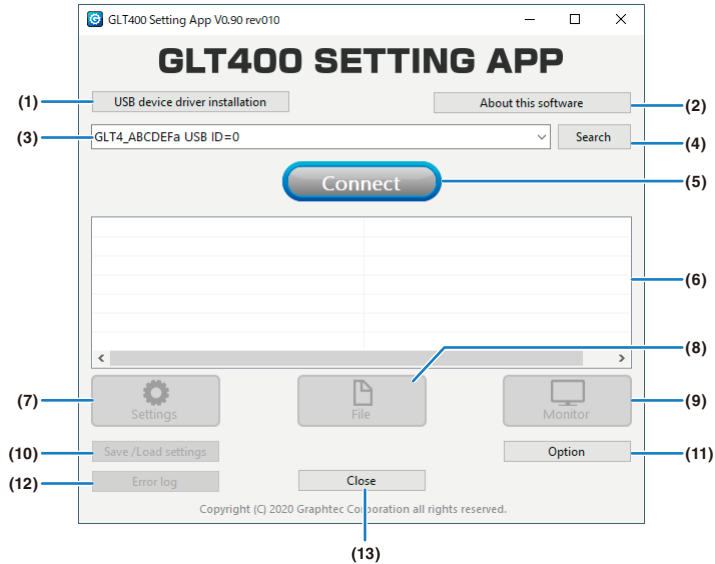

Item	Required environment
(1) USB device driver installation	Install the driver used connect the GLT400 with USB interface. The driver can be installed by executing "Setup.exe" in the opened folder.
(2) About this software	Open the screen for confirming the application-related Help.
(3) List of detected devices	The USB connected to the PC and GLT400 detected from the network are listed. You can also enter the IP address and domain manually. The last connected device is displayed at the top of the list.
(4) Search	Searches for devices.
(5) Connect	Connects to the selected device in the detected device list.
(6) Device information	Displays the information of the connected device. * When performing a USB connection, the connection can be performed only when the identification name and USB ID displayed in the detected device list match the identification name and USB ID of the device to be connected.
(7) Settings	Opens the Settings screen of the GLT400.
(8) File	Displays the screen for operating the files and folders in GLT400.
(9) Monitor	Displays the screen for displaying the digital value of GLT400 and controlling the capturing start.
(10) Save/Load settings	Displays the screen for saving and loading the operation settings and network settings in GLT400.
(11) Option	Displays the Option screen.
(12) Error log	The details of the error that occurred in the GLT400 can be checked.
(13) Close	The screen of this software can be closed and exited.

(2) Settings screen

The settings of GLT400 can be viewed and changed.

The items that you can set differ between STAND-ALONE mode and REMOTE mode.

When the GLT400 is capturing, you can only view the settings.

STAND-ALONE mode

This mode is used for measuring with the GLT400 alone.

All the settings can be viewed and changed.

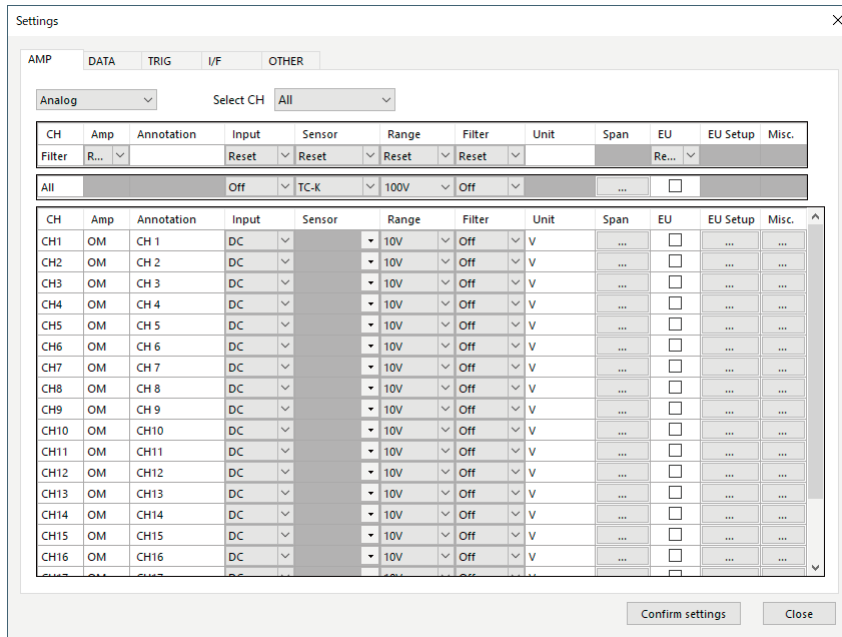

REMOTE mode

This mode is used for connecting the GLT400 as a remote unit of the GL840.

The only IF-related settings for connecting to the GL840 can be set.

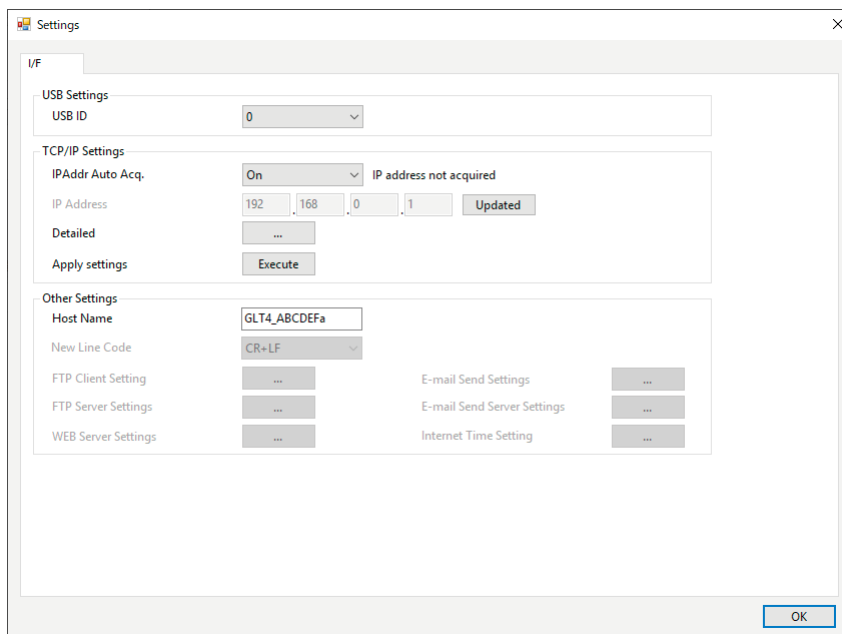

(3) File handling

The status of the internal memory in the GLT400 and SD CARD can be viewed and the files can be downloaded to the PC.

* It is available in STAND-ALONE only.

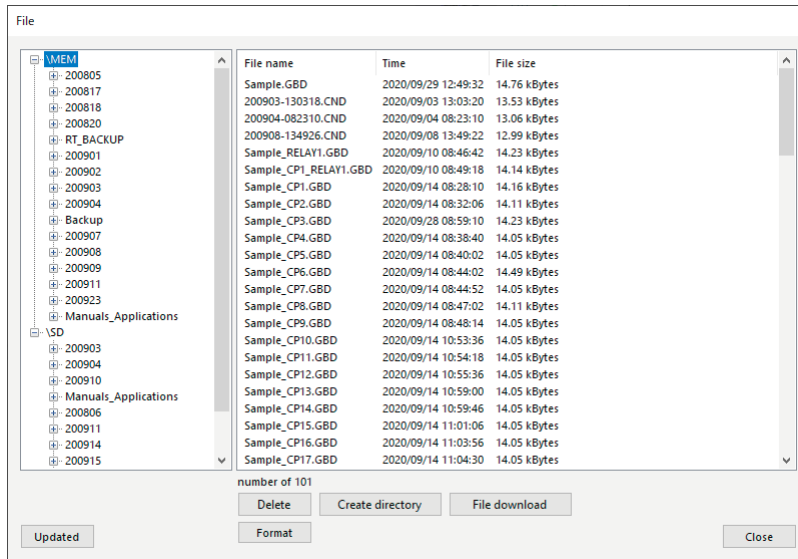

CAUTION

The format function initializes all target drives, so be careful when executing it.

CHECKPOINT

The download function can only download files.

The delete function can delete both files and folders.

Data cannot be copied between the internal memory and SD CARD.

(4) Monitor

The digital value of the GLT400 input signal, capturing status, capturing control, alarm display, pulse clear, error content, etc. can be checked.

Monitor window								
Free running		Screen update rate 500ms	Alarm	1 2 3 4	Alarm clear Clear pulse	Start	Stop	Error log
CH1 CH 1	CH2 CH 2	CH3 CH 3	CH4 CH 4	CH5 CH 5				
-0.001 V	+0.000 V	+0.000 V	-0.001 V	+0.000 V				
CH6 CH 6	CH7 CH 7	CH8 CH 8	CH9 CH 9	CH10 CH10				
+0.000 V	-0.001 V	-0.002 V	-0.001 V	-0.001 V				
CH11 CH11	CH12 CH12	CH13 CH13	CH14 CH14	CH15 CH15				
-0.002 V	+0.000 V	-0.001 V	-0.002 V	-0.001 V				
CH16 CH16	CH17 CH17	CH18 CH18	CH19 CH19	CH20 CH20				
-0.001 V	-0.001 V	-0.001 V	-0.001 V	-0.001 V				

(5) Saving and loading settings

The operation settings and the network settings can be saved and loaded.
The save destination is the internal memory of the GLT400 or the SD CARD.

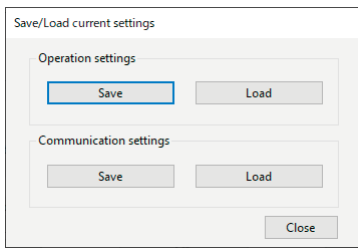

When saving the operation settings or the communication settings, a file that automatically loads the settings when the GLT400 starts up can be generated by checking the "Automatically load file name". This file can only be saved in the SD CARD.

For automatic reading, refer to "3.5 Description of Operation Mode (1) Operation at startup <Automatic reading of operation setting file and network setting file>".

(6) Option settings

Set optional settings. You can change the language and update the firmware of the GLT400.

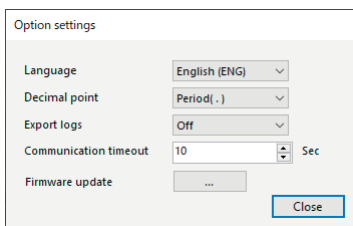

(7) Error log

When errors or warnings occur in the GLT400, you can check them on this screen. Items that you can check in the Error log screen are the occurrence time, error code, and error message. Pressing the Clear log button will clear the error log.

The error log is also cleared in the following cases:

- When the GLT400 is restarted.
- When this software is exited.
- When this software and the GLT400 are disconnected.

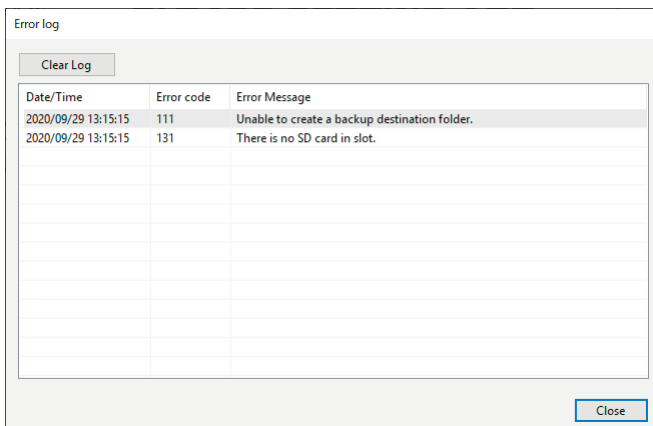

4.3 Settings screen

The settings of GLT400 can be viewed and changed.

The items that you can set differ between STAND-ALONE mode and REMOTE mode.

When the GLT400 is capturing, you can only view the settings.

When characters are entered in the input field, by confirming with the Enter key, the entered settings are sent to the GLT400.

(1) Common settings

Set the settings such as analog input and logic/pulse input for the GLT400.

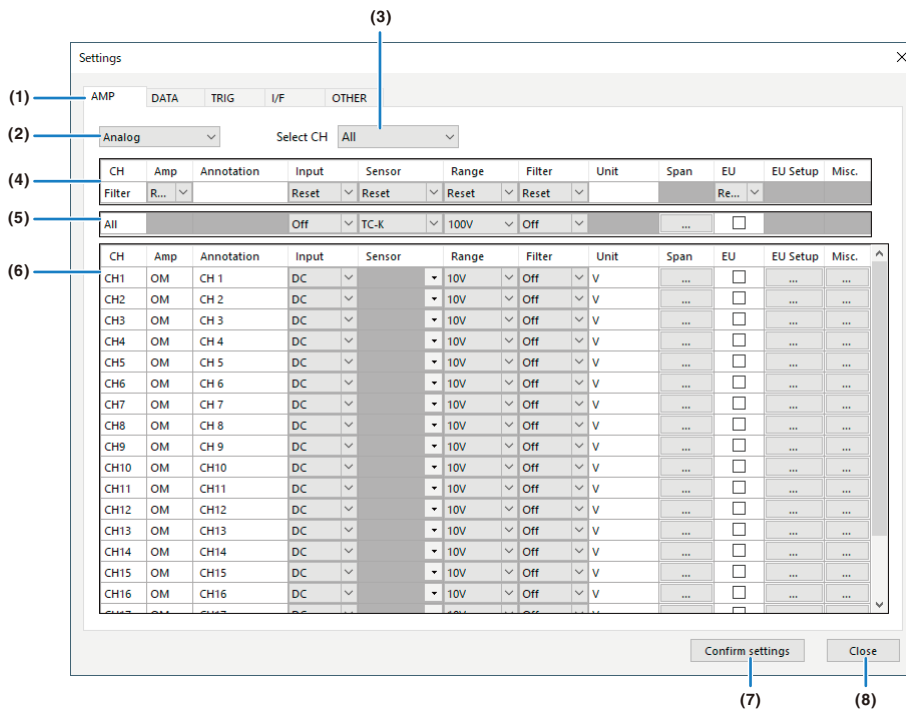

Item	Required environment
(1) Various tabs	Moves to the corresponding setting screen.
(2) Switch amplifier	Switch between analog display and logic/pulse display.
(3) Change analog display CH	Change the display of the analog CH included in the GLT400. You can select whether to display all channels or every 10 channels.
(4) CH filter	Only channels that match the conditions for each channel setting item can be displayed.
(5) All CH change	All the channels that are displayed for each channel setting item can be change at once.
(6) Each CH setting	You can change the settings of the analog channels included in the GLT400 one by one.
(7) Confirm settings	You can check whether capturing can be executed.
(8) Close	The Settings screen is closed and then returns to the GLT400 SETTING APP (Connect) screen.

(2) Amplifier settings

<Analog settings>

Set the settings for analog input signals.

CH	Amp	Annotation	Input	Sensor	Range	Filter	Unit	Span	EU	EU Setup	Misc.
CH1	OM	CH 1	DC		10V	Off	V	...	<input type="checkbox"/>
CH2	OM	CH 2	DC		10V	Off	V	...	<input type="checkbox"/>
CH3	OM	CH 3	DC		10V	Off	V	...	<input type="checkbox"/>
CH4	OM	CH 4	DC		10V	Off	V	...	<input type="checkbox"/>
CH5	OM	CH 5	DC		10V	Off	V	...	<input type="checkbox"/>
CH6	OM	CH 6	DC		10V	Off	V	...	<input type="checkbox"/>
CH7	OM	CH 7	DC		10V	Off	V	...	<input type="checkbox"/>
CH8	OM	CH 8	DC		10V	Off	V	...	<input type="checkbox"/>
CH9	OM	CH 9	DC		10V	Off	V	...	<input type="checkbox"/>
CH10	OM	CH10	DC		10V	Off	V	...	<input type="checkbox"/>
CH11	OM	CH11	DC		10V	Off	V	...	<input type="checkbox"/>
CH12	OM	CH12	DC		10V	Off	V	...	<input type="checkbox"/>
CH13	OM	CH13	DC		10V	Off	V	...	<input type="checkbox"/>
CH14	OM	CH14	DC		10V	Off	V	...	<input type="checkbox"/>
CH15	OM	CH15	DC		10V	Off	V	...	<input type="checkbox"/>
CH16	OM	CH16	DC		10V	Off	V	...	<input type="checkbox"/>

Selection Item		Example of selecting item	
(1) AMP (Amplifier terminal type)		M: Standard terminal WV: Withstand high-voltage high-precision terminal SL: Screwless terminal OM: Terminal of GL820 (* Temperature accuracy may not meet the specifications because it is adjusted by a different unit.)	
(2) Annotation		Up to 31 characters can be entered.	
(3) Input		Off, Voltage, Temperature, Humidity	
(4) Sensor (For temperature only)	Thermocouple	TC-K, TC-J, TC-T, TC-R, TC-E, TC-B, TC-S, TC-N, TC-C (TC-W)	
	Resistance bulb	Pt100, JPt100, Pt1000	
(5) Range	Range	[Voltage]	20, 50, 100, 200, 500mV / 1, 2, 5, 10, 20, 50, 100V / 1-5V
		[Temperature]	100, 500, 2000
		[Humidity]	100% fixed
(6) Filter		Off, 2, 5, 10, 20, 40	
(7) Span	Upper limit	Enter a number	
	Lower limit	Enter a number	
(8) EU Setup (Scaling setting)	Function		Off/On * In case of humidity, it is fixed to Off.
	Measurement value	Upper limit	Enter a number
		Lower limit	Enter a number
	EU output value	Upper limit	Enter a number
		Lower limit	Enter a number
	Decimal point		×0.1, ×1, ×10, ×100, × 1000 for the upper limit of EU output
	Unit selection		Current, length, area, volume, velocity, acceleration, frequency, weight, work, pressure, flow rate, temperature, strain, brightness, concentration
	Unit		(It depends on the unit selection above.)
Arbitrary unit		Enter a character (Up to 8 characters can be entered.)	
(9) Misc	Calculation between channels	Function	Off, On
		Calculation formula	CH-X (+, -, ×, /) CH-Y
		Scaling	/1000000, /1000, ×1, ×1000, ×1000000
		Span upper limit/lower limit	Enter a number
		Unit selection	Current, length, area, volume, velocity, acceleration, frequency, weight, work, pressure, flow rate, temperature, strain, brightness, concentration
		Unit	(It depends on the unit selection above.)
	Execute automatic zero adjustment		▷ Execute * This function is not available in the temperature setting.
	Reset zero adjustment		▷ Execute * This function is not available in the temperature setting.

<Logic/pulse settings>

Set the settings for the logic/pulse input signal.

Selection Item		Example of selection item	
Logic/pulse		Off, Logic, Pulse	
[Logic]	Filter	Off, On	
[Pulse]	Input	Off, rotation speed, accumulation, instantaneous	
	Filter	Off, On	
	Slope	↑H, ↓L	
	EU	Function	Off, On
		Measurement value	Enter a number
		EU output value	Enter a number
		Unit selection	Current, length, area, volume, velocity, acceleration, frequency, weight, work, pressure, flow rate, temperature, strain, brightness, concentration, arbitrary
		Unit	(It depends on the selected unit above.)
Arbitrary unit	Enter a character		
Number of rotation pulses		1 to 10000	

Analog settings

Specifies the conditions for the analog signals.

CHECKPOINT

When you use CH ALL to set an input, range and filter, all channels are set to the same values if the input is the same. Range is set only for the same input channels. However, the range of a channel is not changed if its EU (scaling) is set to On.

Span All Settings is set only for the same range channels.

(2)-1 Input

This is used to select input condition.

Selection item	Description
Off	Input signal measurement is disabled. Waveform or digital value is not displayed.
DC	Used for measuring direct-current voltage.
TEMP	Used for measuring temperature.
RH	Used for measuring humidity with the humidity sensor B-530. In this case, the voltage range will become 1 V, and the EU settings will not be available.

(2)-2 Sensor

This is used to select the thermocouple connected when the temperature is input and type of resistance bulb.

(2)-3 Range

This is used to select the range of measurement.

Input item	Description
DC	20, 50, 100, 200, 500mV / 1, 2, 5, 10, 20, 50, 100V / 1-5V
TEMP	2000, 500, 100
RH	No selection available

Available SPAN Settings

<Voltage Ranges>

Range	Maximum SPAN	Minimum SPAN	Minimum Resolution
20mV	-22.000 to +22.000mV	0.200mV	0.001mV
50mV	-55.00 to +55.00mV	0.50mV	0.01mV
100mV	-110.00 to +110.00mV	1.00mV	0.01mV
200mV	-220.00 to +220.00mV	2.00mV	0.01mV
500mV	-550.0 to +550.0mV	5.0mV	0.1mV
1V	-1.1000 to +1.1000V	0.0100V	0.0001V
2V	-2.2000 to +2.2000V	0.0200V	0.0001V
5V	-5.500 to +5.500V	0.050V	0.001V
10V	-11.000 to +11.000V	0.100V	0.001V
20V	-22.000 to +22.000V	0.200V	0.001V
50V	-55.00 to +55.00V	0.50V	0.01V
100V	-110.00 to +110.00V	1.000V	0.01V
1-5V	-5.500 to +5.500V	0.050V	0.001V

<Temperature Ranges>

Type	Temperature Range	Resolution	Measurement range
R/S	100 F.S.	0.01	0 to 100
	500 F.S.	0.05	0 to 500
	2000 F.S.	0.1	R : 0 to 1600 S : 0 to 1760
B	500 F.S.	0.05	400 to 500
	2000 F.S.	0.1	500 to 1820
K/E/T/J/N	100 F.S.	0.01	-100 to 100
	500 F.S.	0.05	K/E/J/N : -200 to 500
			T : -200 to 400
	2000 F.S.	0.1	K : -200 to 1370
			E : -200 to 800
			T : -200 to 400
		J : -200 to 1100	
		N : -200 to 2000	
C (W)	100 F.S.	0.01	0 to 100
	500 F.S.	0.05	0 to 500
	2000 F.S.	0.1	0 to 2000
Pt	100 F.S.	0.01	-100 to 100
	500 F.S.	0.05	-200 to 500
	2000 F.S.	0.1	Pt100 : -200 to 850
			JPt100/Pt1000 : -200 to 500

<Humidity Range>

Range	Maximum SPAN	Minimum SPAN (p-p)	Minimum Resolution
100%	0 to +110%	1.0%	0.1%

(2)-4 Filter

Selects the range to be measured.

Selection item	Description
Off	No moving average is calculated.
2	A moving average is calculated 2 times per sampling interval.
5	A moving average is calculated 5 times per sampling interval.
10	A moving average is calculated 10 times per sampling interval.
20	A moving average is calculated 20 times per sampling interval.
40	A moving average is calculated 40 times per sampling interval.

<Filter processing>

Filter processing performed on the GLT400 is the moving average shown in the following figure.

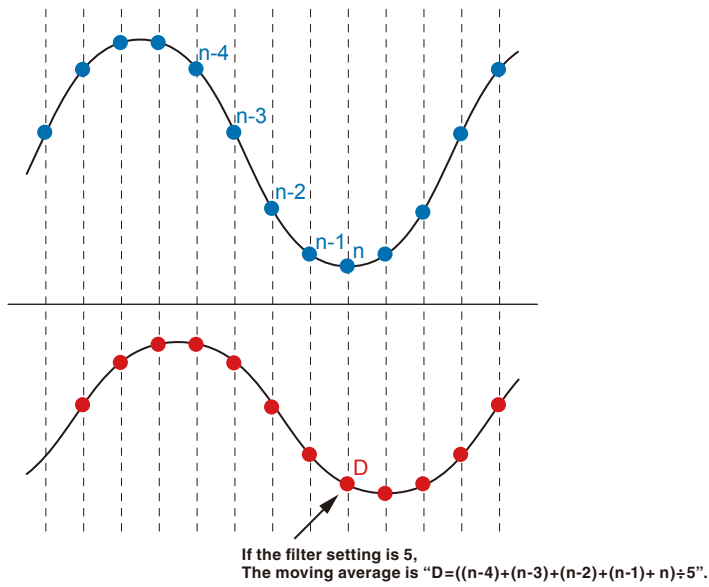

CHECKPOINT

If the sample interval exceeds 30 seconds, the average value of data obtained in a sub-sample (30 seconds) is used.

(2)-5 EU (Scaling settings)

This is used to convert the measured signals to other units.

(1)

Sensor	Range	Filter	Unit	Span	EU	EU Setup	Misc.
...	10V	Off	V	...	<input type="checkbox"/>
...	10V	Off	V	...	<input type="checkbox"/>
...	10V	Off	V	...	<input type="checkbox"/>

<For voltage input>

<For temperature input>

Setting	Description
(1) EU Function	Sets the scaling function to ON or OFF.
(2) Meas. Value (Upper/Lower)	Sets the upper and lower limits of values to be converted. * For temperature input, there is no distinction between upper and lower limits. See the setting examples shown below for details.
(3) EU Output Value (Upper/Lower)	Sets the upper/lower limit output values after conversion. * For temperature input, there is no distinction between upper and lower limits. See the setting examples shown below for details.
(4) Dec pt	Sets the decimal point position for an EU output value.
(5) Select	Selects a specific engineering unit classification. (The following are available.) Cur, Length, Area, Volume, Velocity, Accel, Freq, Mass, Energy, Pressure, Flow, Temp, Strain, Brightness, Concentration
(6) Unit	Selects a unit to be used after conversion. A unit displayed in this field belongs to the classification selected in "Select." To set a unit not displayed in this field, set arbitrary text in "Arbitrary unit." The setting selected in this field is displayed in "Arbitrary unit."
(7) Reads the current temperature measurement value	Substitutes the current measurement value into (2) Measurement value and (3) EU output value. * The value is not substituted when burnout occurs or the scale is exceeded.

CHECKPOINT

- If a message window opens, follow the instruction in the message to change the setting value.
- The Scaling function performs calculation using a ratio of the Meas. Value and EU Output Value settings.
- The digital display shows “++++/----” when the converted value cannot be processed by the GLT400.
- The span may be changed depending on the Scaling settings.
- For temperature input, the offset setting for an input value is used.

Setting example: For voltage input

	Meas. Value	EU Output Value	Dec pt	Unit
Upper limit	+5.000	+20.00	+ xx.xx	rpm
Lower limit	-5.000	-20.00		

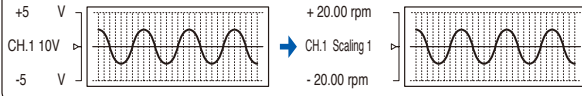

Setting example: For temperature input

Meas. Value	EU Output Value
22.0°C	25.0°C

3°C is always added to the measurement value

(2)-6 Misc. Settings

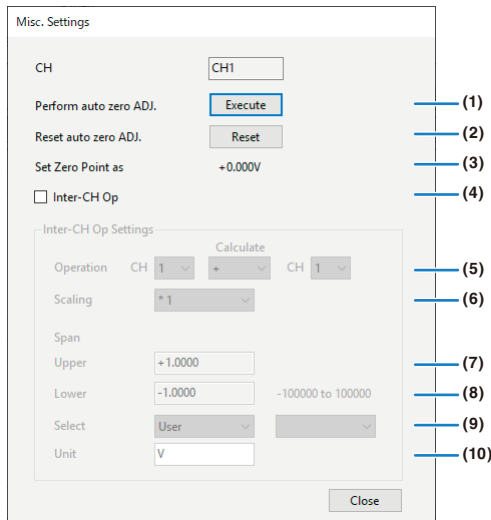

Setting object	Setting	Description
Misc. Settings	(1) Perform auto zero ADJ.	The current input voltage is calculated as a zero point voltage value.
	(2) Reset auto zero ADJ.	Reset the zero point voltage value. * When the temperature is set, this function is not available.
	(3) Set Zero Point as	The zero point voltage value is displayed. * When the temperature is set, this function is not available.

Setting	Description								
(4) Inter-CH Op	Off, On								
(5) Operation	CH-X (Function) CH-Y								
	CH-X	CH1 to CH200							
	Function	Four arithmetic operation functions (+, -, x, /)							
	CH-Y	CH1 to CH200							
(6) Scaling	/1000000, /1000, x1, x1000, x1000000								
	Sets the scaling factor for a calculation result. <Example>								
<table border="1"> <tr> <td>In the case of calculation result = 0.001</td> <td>In the case of calculation result = 1000</td> </tr> <tr> <td>Calculation result x1 = 0.001</td> <td>Calculation result x1 = 1000</td> </tr> <tr> <td>Calculation result x1000 = 1</td> <td>Calculation result / 1000 = 1</td> </tr> <tr> <td>Calculation result x1000000 = 1000</td> <td>Calculation result / 1000000 = 0.001</td> </tr> </table>		In the case of calculation result = 0.001	In the case of calculation result = 1000	Calculation result x1 = 0.001	Calculation result x1 = 1000	Calculation result x1000 = 1	Calculation result / 1000 = 1	Calculation result x1000000 = 1000	Calculation result / 1000000 = 0.001
In the case of calculation result = 0.001	In the case of calculation result = 1000								
Calculation result x1 = 0.001	Calculation result x1 = 1000								
Calculation result x1000 = 1	Calculation result / 1000 = 1								
Calculation result x1000000 = 1000	Calculation result / 1000000 = 0.001								
(7) Span									
(8) Upper/Lower	Sets the upper and lower limits of values of a span in which a waveform should be displayed. The setting value is in reference to a calculation result.								
(9) Select	Selects the unit which indicates the calculation results. Cur, Length, Area, Volume, Velocity, Accel, Freq, Mass, Energy, Pressure, Flow, Temp, Strain, Brightness, Concentration. arbitrary								
(10) Unit	Sets a unit to be used after conversion. Arbitrary text consisting of alphabetical characters and numerical values can be set as a unit. When "Select" or "Unit" is specified, it is reflected in here.								

CHECKPOINT

Calculation results are displayed in volts.
The calculation result for 100 mV + 100 mV is 0.2 V.
Use Scaling to display this result as 200 mV.

Logic and Pulse settings

Makes settings related to digital input.

<For Pulse>

Logic/Pulse Pulse

CH	Input	Filter	Slope	Unit	EU	EU Setup	Pulses per revolution
Pulse1	Revol.	Off	H	RPM	<input type="checkbox"/>	...	360
Pulse2	Counts	Off	H	C	<input type="checkbox"/>	...	360
Pulse3	Inst.	Off	H	C	<input checked="" type="checkbox"/>	...	360
Pulse4	Off	Off	H	C	<input type="checkbox"/>	...	360

<For Logic>

Logic/Pulse Logic

CH	Filter
Logic1	Off
Logic2	Off
Logic3	Off
Logic4	Off

(2)-7 Logic/Pulse

This is used to select the processing method for digital input.

Selection item	Description
Off	Digital input measurement is disabled.
Logic	Digital input is processed as logic signals.
Pulse	Digital input is processed as pulse signals.

(2)-8 Input

This is used to set the pulse measurement mode. This setting is available only if Pulse is selected in (2)-7.

Selection item	Description
Off	Pulse input measurement is disabled.
Revol.	The number of pulses per sample interval is counted and converted to the number of revolutions per minute.
Counts	Captures the cumulative number of pulses for each sampling interval from the start of measurement.
Inst.	Captures the number of pulses for each sampling interval.

(2)-9 Filter

This is used to set the filter for input.

Selection item	Description
Off	Disables hardware filter.
On	Enables hardware filter. It is effective in a noisy environment. The filter is approximately 30 Hz (-3 dB).

(2)-10 Pulse Slope

This is used to set the slope (direction) to count the number of pulses. This setting is available only if Pulse is selected in (2)-7.

Selection item	Description
↑ H	Counts the rising edges of pulses.
↓ L	Counts the falling edges of pulses.

(2)-11 EU (Engineering unit setting)

This is used to convert the measured signals to other units. This setting is available only if Pulse is selected.

(1)

CH	Input	Filter	Slope	Unit	EU	EU Setup	Pulses per revolution
Pulse1	Revol.	Off	H	RPM	<input type="checkbox"/>	...	360
Pulse2	Counts	Off	H	C	<input type="checkbox"/>	...	360
Pulse3	Inst.	Off	H	C	<input checked="" type="checkbox"/>	...	360
Pulse4	Off	Off	H	C	<input type="checkbox"/>	...	360

Engineering unit setting

CH:

Engineering unit setting

Meas. Value: EU Value:

Setting:

Select:

Unit:

Limits:

OK Cancel

(2)(3) (4)(5) (6)

Setting	Description
(1) EU Function	Sets the scaling function to ON or OFF.
(2) Setting	Sets a value to be converted.
(3) EU Value	Sets an output value after conversion.
(4) Select	Selects a specific engineering unit classification. (The following are available.) Cur, Length, Area, Volume, Velocity, Accel, Freq, Mass, Energy, Pressure, Flow, Temp, Strain, Brightness, Concentration.
(5) Unit	Selects a unit to be used after conversion. A unit displayed in this field belongs to the classification selected in "Select." To set a unit not displayed in this field, set arbitrary text in "Arbitrary unit". The setting selected in this field is displayed in "Arbitrary unit".
(6) User Unit	Sets a unit to be used after conversion. Arbitrary text consisting of alphabetical characters and numerical values can be set as a unit. When "Select" or "Unit" is specified, it is reflected in here.

CHECKPOINT

- If a message window opens, follow the instruction in the message to change the setting value.
- The Scaling function performs calculation using a ratio of the Meas. Value and EU Output Value settings.
- The digital display shows “++++/----” when the converted value cannot be processed by the GLT400.
- The span may be varied depending on the scaling settings.

Setting example

Meas. Value	EU Output Value	Dec pt	Unit
1000	800	+ xx.xx	rpm
0	200		

(2)-12 Number of pulses per revolution

When setting the pulse input to the number of revolutions, set the number of pulses per revolution.

As the number of pulses per revolution set here is 1 revolution, the number of revolutions per minute (RPM) is calculated.

For example, if “100” is set, 1 rotation is judged when 100 pulses have been input.

<Calculation formula>

Number of revolutions (RPM) = Pulse input frequency ÷ Number of pulses per revolution x 60 (1 minute)

<Example>

Number of pulses per revolution: 100 (1 rotation is judged when 100 pulses have been input.)

Pulse input: 1000 Hz (1000 pulses per sec.)

Number of revolutions: 600 RPM (600 rotation per min.)

Setting	Description
Number of pulses per revolution	1 to 10000

(3) DATA settings

This is used to specify capture-related items and calculations.

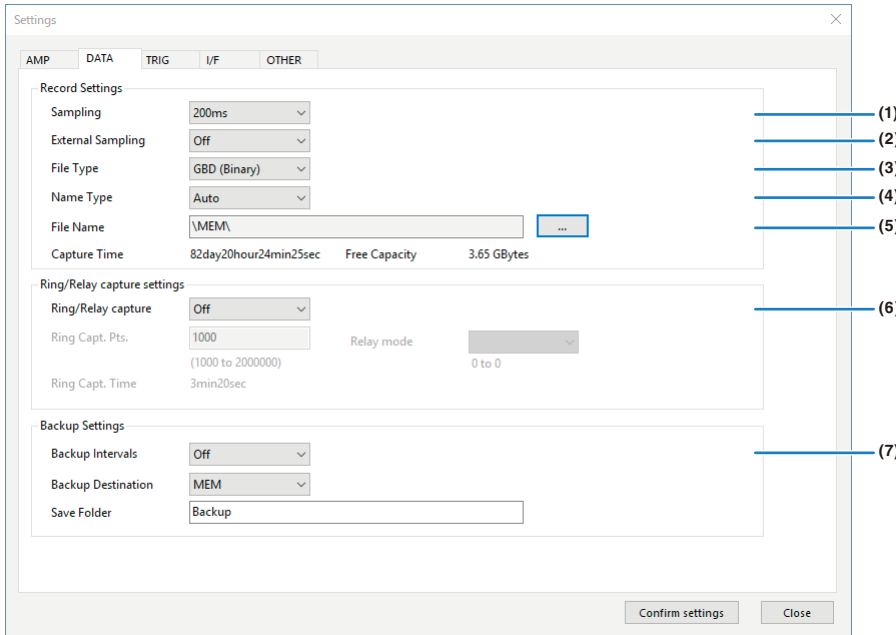

Setting	Selections available
(1) Sampling	10, 20, 50, 100, 125, 200, 250, 500ms, 1, 2, 5, 10, 20, 30s, 1, 2, 5, 10, 20, 30min, 1h * Available sampling intervals vary depending on the input settings and the number of channels to be used. * Refer to "(3)-1 Sampling Interval" for details.
(2) External Sampling	Off, On
External Sampling	Off, On * It can be set only when external sampling is set to On.
(3) File Type	Binary (GBD), Text (CSV)
(4) Name Type	Auto, Arbitrary, Serial number
(5) File Name	Capture destination: Internal memory or SD CARD Folder: Text input (if the naming method is Auto) File: Text input (if the naming method is Arbitrary or Serial number)
(6) Ring/Relay capture settings	Off, Ring, Relay
Ring capture	Number of recording points
Relay mode	Relay time, Relay capacity
(7) Backup Settings	
Backup Interval	Off, 1, 2, 6, 12, 24 hours, Each file (* Each file can be selected only when the backup destination is set to FTP and the captured file is deleted when the backup of the FTP client settings is activated normally.)
Backup Destination	Internal memory, SD CARD, FTP
Save Folder	Folder name

(3)-1 Sampling interval

This is used to set the sampling interval for data capture.

The table below shows the number of measuring channels and sampling interval values that can be set. If data fluctuate due to noise, set the sampling interval to a value which enables the digital filter function.

Number of Measuring Channels*1	Allowed Sampling Interval	Sampling Interval which enables Digital Filter*3
1CH	10ms or slower *2	50ms or slower
2CH	20ms or slower *2	125ms or slower
3CH to 5CH	50ms or slower *2	250ms or slower
6CH to 10CH	100ms or slower	500ms or slower
11CH to 20CH	200ms or slower	1s or slower
21CH to 50CH	500ms or slower	2s or slower
51CH to 100CH	1s or slower	5s or slower
101CH to 200CH	2s or slower	10s or slower

*1: The number of measurement channels is the number of channels for which the input settings for standard terminal, withstand high-voltage high-precision terminal, and screwless terminal are set to other than OFF.

*2: When the temperature setting is performed in 10, 20, or 50 ms sampling interval, the data capture cannot be performed.

*3: It is necessary to accurately set the digital filter to the AC power frequency to be used. Refer to "(6)-6 AC line frequency" below to set the correct settings.

(3)-2 External sampling

This is used to enable or disable external sampling.

When the external sampling function is enabled, data is captured at the shortest intervals and retained temporarily.

This retained data is updated at the shortest intervals.

On receiving an external sampling pulse, the retained data is written to the internal memory or SD CARD. (See the following figure.)

Therefore, the maximum error in time between the actually captured data and the external sampling pulse is the same as the shortest interval.

Refer to the next section, "(3)-3 AC line filter" for details on the shortest interval.

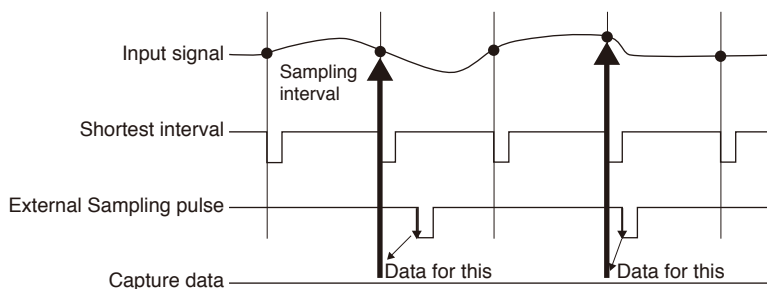

CHECKPOINT

If the external sampling function is ON, the external input cannot be selected for the trigger setting.
If the external input has already been set, the trigger will be set to Off.

To measure a noisy signal, set the AC line filter to On as described in "(3)-3 AC line filter" below.

(3)-3 AC line filter

This is used to enable or disable the AC line filter while external sampling is enabled.

Enable this setting to enable the digital filter. When you use external sampling and measure signals with high noise levels, set the AC line filter to ON.

The shortest interval is displayed under the settings.

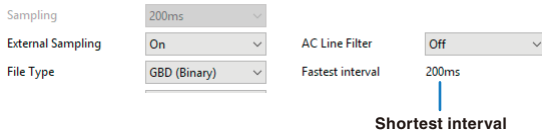

The shortest interval is as shown in the following table:

Number of Measuring Channels *1	Shortest interval	
	AC line filter (Digital filter) OFF	AC line filter (Digital filter) ON
1CH	10ms	200ms
2CH	20ms	500ms
3CH to 5CH	50ms	1s
6CH to 10CH	100ms	1s
11CH to 20CH	200ms	2s
21CH to 50CH	500ms	5s
51CH to 100CH	1s	10s
101CH to 200CH	2s	20s

* The number of measurement channels is the number of channels for which the input settings for standard terminal, withstand high-voltage high-precision terminal, and screwless terminal are set to other than OFF.

(3)-4 Captured data file name

This is used to select the name of a file or folder to which you want to save capture data.

Setting	Description
File Type	Sets the file format used to save data. GBD: Creating a data file in Graphtec's proprietary binary format * It is not possible to change the data. CSV: Creating a data file in text format
Name Type	Sets how a data file should be named. Automatic: The folder and file name are automatically specified. Example: When capturing starts at 12:34:56 on July 1 2020 <Folder name>.....200701 <File name>.....20200701-123456.GBD * When 50 or more files are created in the folder during repeat capturing, the folder with the serial number is created automatically. Example: \200701\1\20200701-123456.GBD Arbitrary: Data is captured to a file with an entered file name. Serial number: A file is created with an arbitrary file name that has been entered, followed by a Serial number. Example: If the file name is "TEST" First file: TEST_SER1.GBD Second file: TEST_SER2.GBD Third file: TEST_SER3.GBD * If the same file name already exists, _CP* is added to the end of a file name to prevent overwriting. The asterisk (*) represents a number. Example: TEST_CP1.GBD
Captured data file name	Specifies the file in the capture destination (or save destination).

CAUTION

The file should be saved in the folder you created. When the data files are continued to be saved in the root folder, the data file may be not saved regardless of the memory remaining capacity due to the limitations of the file system.

CHECKPOINT 

Changing the sampling interval, capture destination, number of measuring channels (number of channels for which the input is not Off), etc. will change the Capture Space and Capture Time on the screen.

The download function is available for file only. After checking, if the measurement time exceeds the capturing time, please take one of the following measures.

- Change the sampling interval.
- In the case of SD CARD, change to the SD CARD with more free space.

Capture Time	82day20hour24min25sec	Free Capacity	3.65 GBytes
--------------	-----------------------	---------------	-------------

Capture Space: Displays the amount of memory space available for data capture.

Capture Time: Displays time available for at the SD CARD.

* The Capture Time is calculated for 2 GB at the maximum.

(3)-5 Ring/Relay capture settings

Ring Capture Function

Ring/Relay capture settings

Ring/Relay capture: Ring (1)

Ring Capt. Pts.: 1000 (1000 to 2000000) (2)

Ring Capt. Time: 3min20sec (3)

Setting	Description
(1) Ring/Relay capture	Set the capture function. Off: The capture function is disabled. Ring: Perform the ring capturing. (For details, refer to the following figure.) Relay: The data is continuously captured in separated files without missing data.
(2) Ring Capture Points	To use the ring capturing function, specify the number of data points per one file. (For details, refer to the following figure.)
(3) Ring Capture Time	Display the measurement time that can be captured in one file when the ring capturing function is enabled (On).

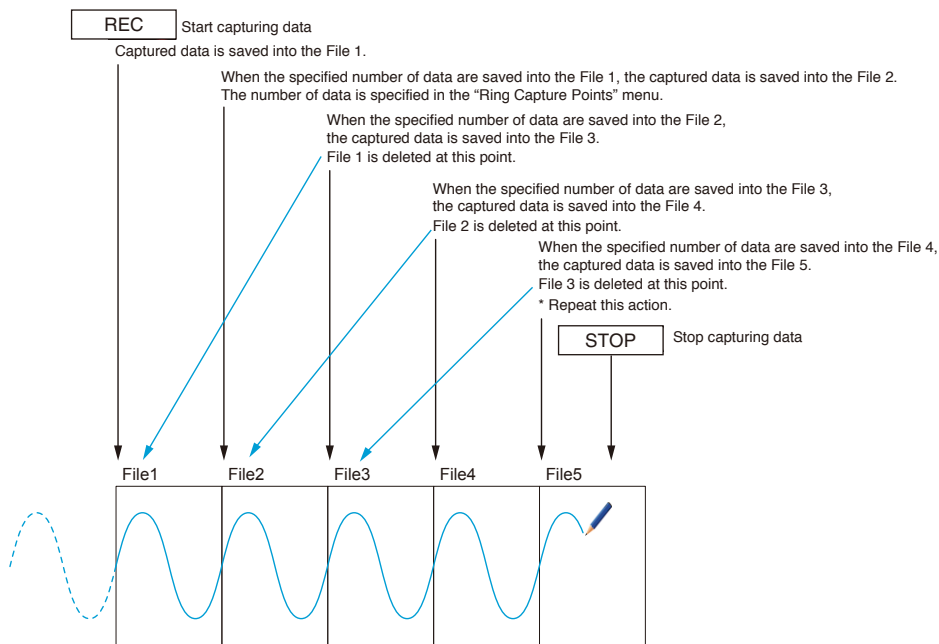

When capturing is stopped at the STOP point in the above, the File 4 and the File 5 are remained. These files are consolidated into one file and it is saved. Then the ring capture is completed.

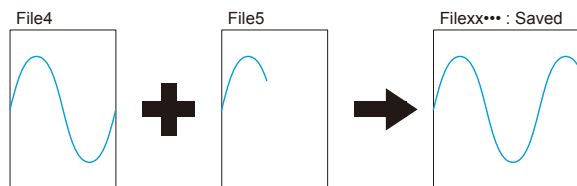

CHECKPOINT

Twice as many files as the Number of Ring Capture Points will be created at the maximum.

Relay Capture Function

- Ring/Relay capture settings

Ring/Relay capture	Relay			(1)
Ring Capt. Pts.	1000	Relay mode	Relay time	(2)
	(1000 to 2000000)	Relay time	01:00 (01:00 to 24:00)	(3)
Ring Capt. Time	3min20sec	Relay capacity	1.04 MBytes	(4)

Setting	Description
(1) Relay capture	Data is captured consecutively for each file of up to 2000 MB continuously.
(2) Relay mode	Set the mode for performing the relay processing. Time: After the set time has elapsed, the relay processing is performed. Capacity: When the file has reached the set file size, relay processing is performed.
(3) Relay time	Set the relay time when relay mode is set to "Time". 1 hour 00 minutes to 24 hours 00 minutes
(4) Relay capacity	Set the file size when relay mode is set to "Capacity". 100MB to 2000MB * Estimated time for capturing with the set file size is displayed as "Relay time".

The captured data is continuously captured by files separated for each set relay without losing data. (Maximum capture capacity in one file is 2000MB.)

(3)-6 Backup setting

The GLT400 has a function that periodically backs up captured data.
(See the figure below)

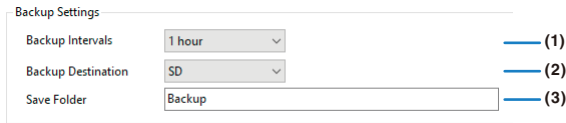

Setting	Description
(1) Backup Intervals	Sets the backup interval for captured data. Off, 1, 2, 6, 12, 24 hours, or Off, By file * "By file" can be set under the following conditions. • Backup destination is "FTP" • "Recorded file when backup is successful" in the FTP Client Setting is set to "Delete".
(2) Backup Destination	Sets the backup destination for captured data. Refer to "FTP Client Settings" in "(5)-5 Other settings".
	Internal memory Backs up the captured data to the internal memory. This is used only when capturing to the SD CARD.
	SD CARD Backs up the captured data to the SD CARD. This is used only when capturing to the internal memory.
	FTP Backs up data to an FTP server on the network. *The FTP server settings must be made using the FILE menu. (Refer to "FTP Server Settings" in "(5)-5 Other settings".)
(3) Save Folder	Sets the folder for saving a backup file. * This must be a folder on the internal memory, SD CARD or an FTP server. Example: \BACKUP\20200201

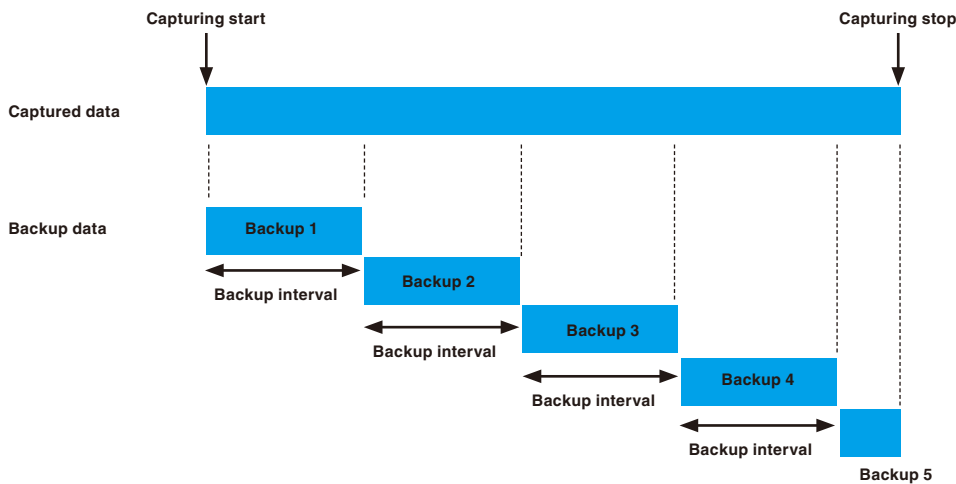

CHECKPOINT

If ring capture is On, the backup function is not available.

It takes a time for writing after capturing was stopped when many channels are captured, when interval sampling is fast, when backup interval is long, because the backup data size becomes large.

Sometimes the backup will be failed when the backup data is saved to the FTP server via the wireless LAN by condition of Wifi communication.

When the sampling interval is faster than the 100 ms the backup of CSV format is not able to perform.

When the capture in CSV format and backup function are enabled, SD CARD replacement for capturing and Relay capturing cannot be performed.

When the external sampling function is ON the backup function is not able to perform.

The media cannot be replaced when saving to an FTP server.

When using trigger repeat, the repeat interval may become long because the next capturing is started after the backup writing is completed.

(4) TRIG settings

This is used to specify trigger conditions and alarms.

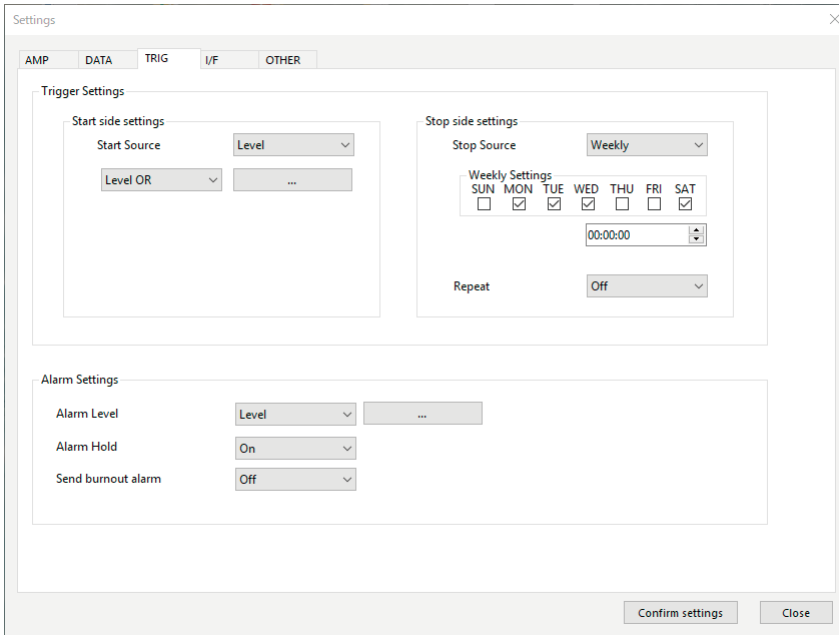

Setting		Selections available
Start Side Source Setting		Off, Level, Alarm, External Input, Time, Day, Duration
[Level]	Mode	Analog: Off, ↑ H, ↓ L, Window In, Window Out Logic: Off, ↑ H, ↓ L Pulse: Off, ↑ H, ↓ L, Window In, Window Out
	Combination	Level OR, Level AND, Edge OR, Edge AND
	Level	Set numeric value
[Alarm]	Alarm port number	1, 2, 3, 4
[Date]	Date	From 2020.1.1 to 2035.12.31
	Time	From 0:0:0 to 23:59:59
[Weekly]	Day of week	Off or On setting for each of Sunday through Saturday
	Time	From 0:0:0 to 23:59:59
[Duration]		From 0:0:1 to 9999:59:59
Stop Side Source Setting		Off, Level, Alarm, External Input, Time, Day, Duration
[Level]	Mode	Analog: Off, ↑ H, ↓ L, Window In, Window Out Logic: Off, ↑ H, ↓ L Pulse: Off, ↑ H, ↓ L, Window In, Window Out
	Combination	Level OR, Level AND, Edge OR, Edge AND
	Level	Set numeric value
[Alarm]	Alarm port number	1, 2, 3, 4
[Date]	Date	From 2020.1.1 to 2035.12.31
	Time	From 0:0:0 to 23:59:59
[Weekly]	Day of week	Off or On setting for each of Sunday through Saturday
	Time	From 0:0:0 to 23:59:59
[Duration]		From 0:0:1 to 9999:59:59
Repeat Capturing		Off, On
Alarm Level Settings	Mode	Analog: Off, ↑ H, ↓ L, Window In, Window Out Logic: Off, ↑ H, ↓ L Pulse: Off, ↑ H, ↓ L, Window In, Window Out
	Level	Set numeric value
	Output	1, 2, 3, 4
	Detection Method	Level, Edge
	Alarm Hold	Held or Not held
	Send Burnout Alarm	Sent or not sent

(4)-1 Start side source setting

This is used to specify trigger conditions to start data capture.

Selection item	Description
Off	Starts capturing data unconditionally when you press the [Start/Stop] key.
Level	Starts capturing data when a specified level is reached. -> When Level is selected, the condition for each channel must be set. Refer to "Trigger Level Settings/Alarm Level Settings" described below.
Alarm	Starts capturing data when an alarm is generated in the specified alarm port.
External Input	Starts capturing data when an input signal is received from an external trigger terminal. * A trigger is established at a transition from 5 V (open) to 0 V (shorted to the ground). A falling edge operation occurs.
Date	Starts capturing data when specified date and time arrives.
Weekly	Starts capturing data at the specified time on days of week for which On is set. Example: On is set for Mon, Tue, Wed, Thu, and Fri, Off is set for Sun and Sat, and 9:00 is set as the time. Starts capturing data at 9:00 on weekdays. Does not start capturing data on Sat and Sun.
Duration	Starts capturing data when a specified length of time elapses.

(4)-2 Stop side source setting

This is used to specify trigger conditions to stop data capture.

Selection item	Description
Off	Stops capturing data unconditionally when you press the [Start/Stop] key.
Level	Stops capturing data when a specified level is reached. -> When Level is selected, the condition for each channel must be set. Refer to "Trigger Level Settings/Alarm Level Settings" described below.
Alarm	Stops capturing data when an alarm is generated in the specified alarm port.
External Input	Stops capturing data when an input signal is received from an external trigger terminal. * A trigger is established at a transition from 5 V (open) to 0 V (shorted to the ground). A falling edge operation occurs.
Date	Stops capturing data when specified date and time arrives.
Weekly	Stops capturing data at the specified time on days of week for which On is set. Example: On is set for Mon, Tue, Wed, Thu, and Fri, Off is set for Sun and Sat, and 9:00 is set as the time. Stops capturing data at 9:00 on weekdays. Does not stop capturing data on Sat and Sun.
Duration	Stops capturing data when a specified length of time elapses.

CHECKPOINT

- When External Input is used as the trigger source, no stop trigger is accepted for 50 ms after capture is started.
- When the start trigger is External Input, data is captured at sampling intervals (fixed to 30 seconds if they are more than 30 seconds) and retained temporarily.
This retained data is refreshed at sampling intervals (fixed to 30 seconds if they are more than 30 seconds).
Since the external trigger input operation conducts detection at 10 ms intervals asynchronously from sampling, the retained data becomes the first point when an external trigger is detected. Starting from this point, data is captured at sampling intervals.
- Even when the stop trigger is sent from an external device, the detection is executed in 10 ms. The data capture is stopped when the stop trigger is received.

(4)-3 Repeat capturing

This is used to enable or disable the repeat function to conduct repeated capturing.

Selection item	Description
Off	The repeat function is disabled.
On	The repeat function is enabled. After one capture is ended, the next capture is started (If the start side source setting is not Off, the GLT400 waits for a trigger). Also, when setting the specified time, the date and time must be set. However, when the repeat function is enabled (On), the specified time is changed to the time display. It occurs the trigger once a day.

(4)-4 Alarm level settings

This is used to set alarm generation conditions, output destination, etc.

When the conditions specified here are met, the alarm output terminal (for which an output destination number must be specified for each channel) outputs an alarm.

For the CH condition settings, refer to “Trigger Level Settings/Alarm Level Settings” described below.

(4)-5 Alarm hold

If "Alarm retention" is selected here, once the established conditions have been met the alarm status will not be cleared, regardless of whether or not the conditions continue to be met. (Press and hold the CLEAR key or press the alarm clear button in the monitor window to cancel.)

(4)-6 Send burnout alarm

The alarm is output from the alarm output terminal by selecting “Sent” when the burnout occurs (Refer to “(6)-5 Burnout) described below.

Trigger level settings / Alarm level settings

Specifies detailed conditions for each channel when the start and stop side source settings are Level. The configuration of the level trigger is as shown in the figure below.

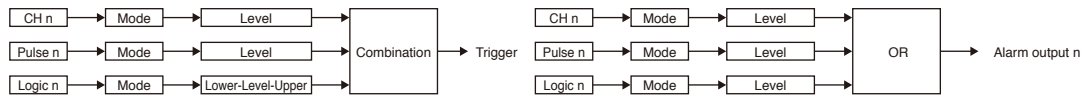

* Pulse and Logic are switchable.

* Pulse and Logic are switchable.

* Specify an alarm output destination for each channel and Pulse/Logic. Each of the alarms is ORed at the output destination.

Example: If you specify 1 as the output destination of 1CH and 2CH and 2 as that of 3CH and 4CH, Alarm Output 1 occurs when one of 1CH and 2CH meets the conditions, and Alarm Output 2 occurs when one of 3CH and 4CH meets the conditions.

Setting	Description
(1) Combination <For Trigger>	Sets a combination of trigger conditions set for each channel. Level OR : Starts (stops) capturing data when at least one of the specified trigger conditions is met. Each condition is Level operation. Level AND : Starts (stops) capturing data when all of the specified trigger conditions are met. Each condition is Level operation. Edge OR : Starts (stops) capturing data when at least one of the specified trigger conditions is met. Each condition is Edge operation. Edge AND : Starts (stops) capturing data when all of the specified trigger conditions are met. Each condition is Edge operation.
Detection method <For Alarm>	Level: Each condition is Level operation. Edge: Each condition is Edge operation.
(2) Mode	Sets a trigger comparison mode for each channel. Off : Disables triggers for the setting channel. ↑ H (rising): A trigger is generated when the input signal exceeds the specified level. ↓ L (falling): A trigger is generated when the input signal falls below the specified level. Win In : Used to specify the upper and lower limits for each channel. When the input signal level is (or comes) between these limits, a trigger is generated. * This setting is not available for Logic CH. Win Out: : Used to specify the upper and lower limits for each channel. When the input signal level is (or goes) out of these limits, a trigger is generated. * Logic CH has no settings. * This cannot be set when the input is set to Off or the calculation between channels is set to On.
(3) Level	Sets a trigger comparison level. If the mode is ↑ H (rising) or ↓ L (falling), set one comparison level. If the mode is Win In or Win Out, set two comparison levels.
(4) Alarm Output	1 to 4 Set the output destination to one of the alarm output terminals 1 to 4.

Level and Edge operations

In level operation, if the conditions are met at the start of capturing, the trigger condition is considered to be established.

In edge operation, even if the conditions are met at the start of capturing, it is not considered to be established. A trigger is assumed to be generated when the trigger conditions, after not being met, are met again.

* A trigger is still assumed to be generated even if the trigger conditions are met once in the Edge operation and then are no longer met.

<Ex.> Level action If the START key is pressed here

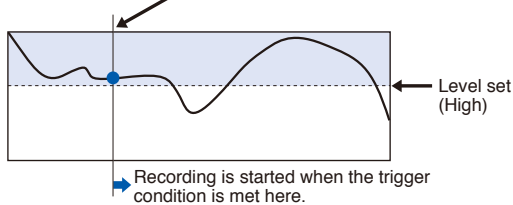

<Ex.> Edge action If the START key is pressed here

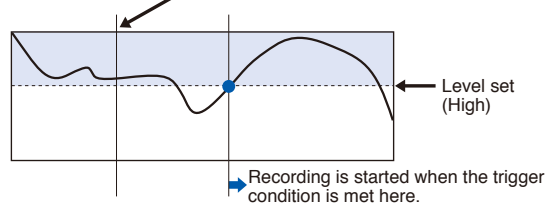

<Ex.> Level AND action

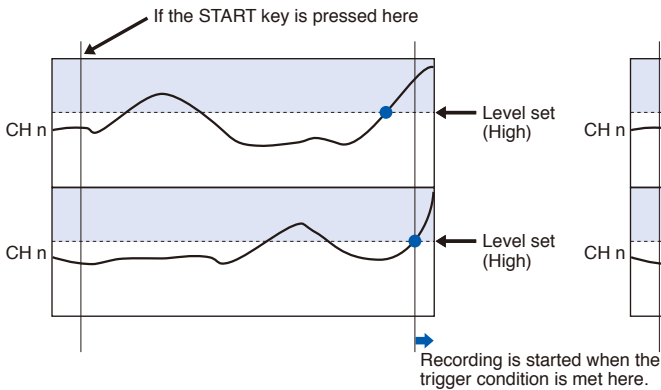

<Ex.> Edge AND action

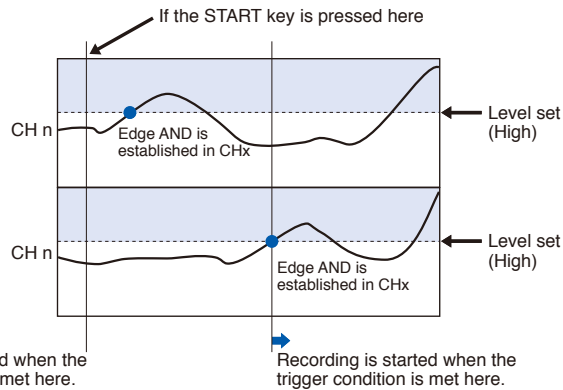

Operation mode (Rising, Falling, Window In, Window Out)

Rising : A trigger/alarm is generated when the input signal is higher than the specified level.

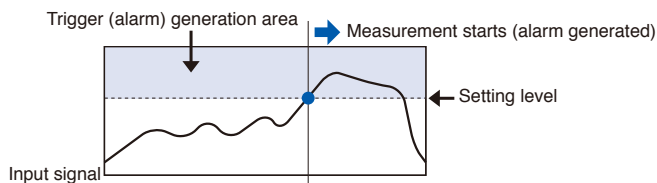

Falling : A trigger/alarm is generated when the input signal is lower than the specified level.

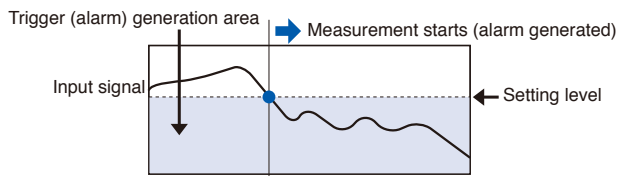

Win In : Used to specify the upper and lower limits for each channel. When the input signal level comes (or is) between these limits, a trigger/alarm is generated.

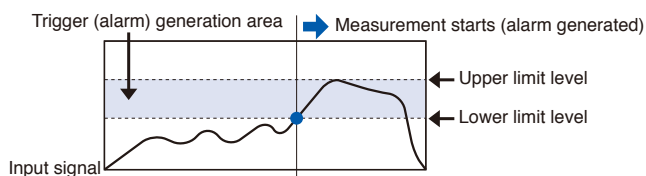

Win Out : Used to specify the upper and lower limits for each channel. When the input signal level goes (or is) out of these limits, a trigger/alarm is generated.

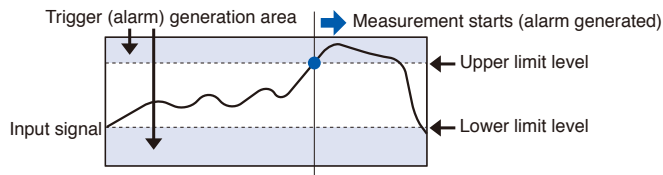

Dead zones of trigger and alarm levels

Trigger and alarm levels are provided with a dead zone in order to prevent false detection due to noise. The following figure shows the dead zone.

<Mode: Rising>

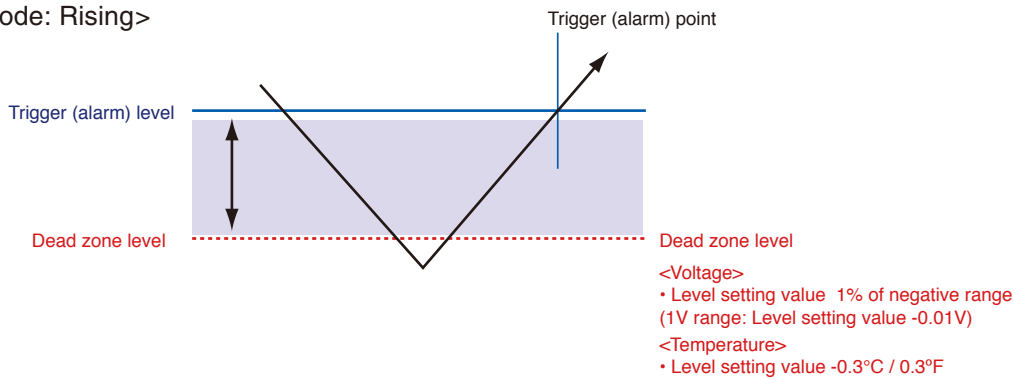

<Mode: Falling>

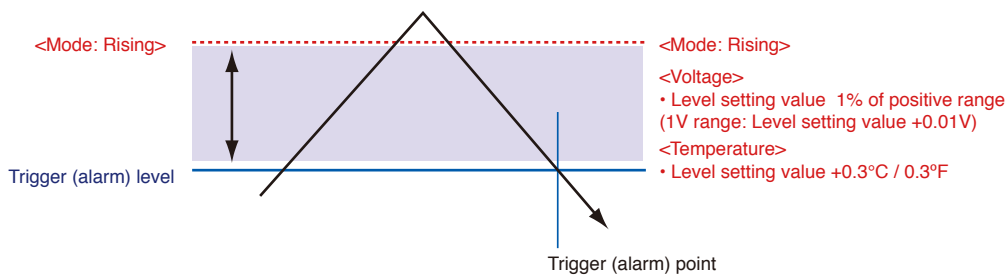

CHECKPOINT

- The upper limit values within the mode range and the lower limit values out of the mode range are dead zone level as well.
- When the detected alarm drops below the dead zone level, it is cleared. (When the alarm is not retained)
<Example> When measuring temperature, the level released after the alarm generated is shown below.
 - Rising setting: Setting value -0.3°C / 0.3°F
 - Falling setting: Setting value +0.3°C / 0.3°F
- In the case of pulse, dead zone is not provided.

(5) Interface settings

This menu is used to specify conditions for PC connection.

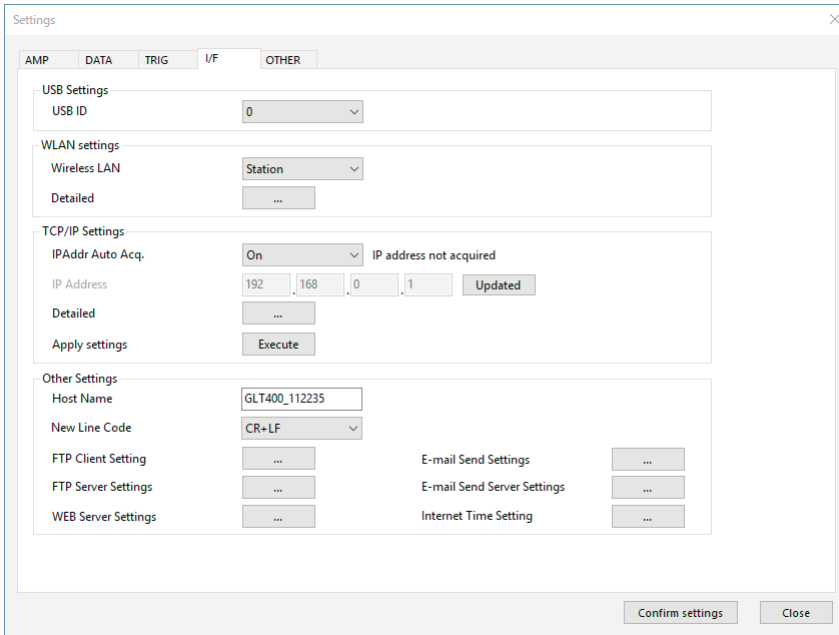

Setting		Selections available	
USB Settings	USB ID	0 to 9	
Wireless LAN settings * When connecting wireless LAN (option)		Off, Access point, Station	
Wireless LAN settings	When setting the station	Easy Connection (WPS)	▷ Execution
		SSID input	Enter the character string
		SSID search	▷ Execution
		Encryption method	None, WEP, WPA-PSK/WPA2-PSK
		WEP key, password	Enter the character string
		Apply settings	▷ Execution
		Connection	▷ Execution
	When setting the access point	SSID input	Enter the character string
		Encryption method	None, WEP, WPA-PSK/WPA2-PSK
		WEP key, password	Enter the character string
		Channel	1ch to 13ch
		Stealth	Off, On
		Apply settings	▷ Execution
		TCP/IP Settings	
IP Addr Auto Acq.		On, Off	
IP address		0 to 255. 0 to 255. 0 to 255. 0 to 255 (Only when IP Address Auto Acquisition is not used)	
Detailed	IP address	0 to 255. 0 to 255. 0 to 255. 0 to 255 (Only when IP Address Auto Acquisition is not used)	
	Subnet mask	0 to 255. 0 to 255. 0 to 255. 0 to 255 (Only when IP Address Auto Acquisition is not used)	
	Port Number	1024 to 65535	
	Gateway	0 to 255. 0 to 255. 0 to 255. 0 to 255 (Only when IP Address Auto Acquisition is not used)	
	DNS address	0 to 255. 0 to 255. 0 to 255. 0 to 255 (Only when IP Address Auto Acquisition is not used)	
	Disconnect when GLT400 is not communicating	Off, 10 sec, 30 sec, 1 min, 10 min, 30 min, 1 hr	
	Apply settings	▷ Execution	
Apply settings		▷ Execution	

Setting		Selections available		
Other Settings	Host Name	Enter a string of up to 15 characters		
	New Line Code	CR+LF, LF, CR		
	FTP Client Settings	Easy FTP Client Settings	Manual setting, GRM-ONE BASIC	
		FTP server	Enter the character string	
		User name	Enter the character string	
		Password	Enter the character string	
		Port Number	0 to 65535 * Depends on the encryption method. Off: 21 Explicit encryption (Explicit): 21 Implicit encryption (Implicit): 990	
		PASV mode	Off, On	
		Encryption method	Off, Explicit encryption (Explicit), Implicit encryption (Implicit)	
		Recorded file when backup is successful	Leave, Delete	
		Apply settings	▷ Execution	
		FTP server connection test	▷ Execution	
	FTP Server Settings	Anonymous access	Disable or Enable	
		User name	Enter the character string	
		Password	Enter the character string	
		Port Number	0 to 65535 * Depends on the encryption method. Off: 21 Explicit encryption (Explicit): 21 Implicit encryption (Implicit): 990	
		Encryption method	Off, Explicit encryption (Explicit), Implicit encryption (Implicit)	
		Apply settings	▷ Execution	
	WEB Server Settings	Port Number	0 to 65535 * Depends on the encryption method. Off: 80 On: 443	
		Basic authentication	Off, On	
		User name	Enter the character string	
		Password	Enter the character string (Default GLT400)	
		Encryption (HTTPS)	Off, On	
		Apply settings	▷ Execution	
	E-mail Send Setting	Destination setting	To	Enter the character string
			CC1 to CC3	Enter the character string
			Subject	Enter the character string
		Notification setting	Alarm	Off, On
			Low communication strength	Off, On
			Capturing destination free space	Off, On
	Periodic notifications	Off, 1 hour, 2 hours, 3 hours, 6 hours, 12 hours, Specified time		
	Outgoing mail server settings	Easy Send E-mail Setting	Manual setting, Gmail, Office365	
		Send (SMTP) Server Name	Enter the character string	
		SMTP port number	0 to 65535	
		Time zone	UTC-12:00 to UTC+13:00	
		SMTP authentication method	Off, SMTP-AUTH	
		SMTP encryption	Off, StartTLS, SSL	
		SMTP-AUTH	Off, PLAIN, LOGIN, CRAM-MD5, DIGEST-DM5	
		SMTP user name	Enter a string of up to 63 characters	
		SMTP password	Enter a string of up to 31 characters	
		E-mail address	Enter up to 63-character string	
		Sending test	▷ Execution	
Network time setting		Network time	Off, On	
		Time server	Enter the character string	
	Time zone	-12:00 to +13:00 (1 hour unit)		
	Synchronized time	00:00 to 23:59		
	Synchronous mode	Synchronize immediately, Synchronize gradually		
	Connection test	▷ Execution		

(5)-1 USB settings

Set the USB ID number of GLT400.

Specify a number from 0 to 9.

To control more than one GLT400 unit with one PC, assign a unique USB ID to each of them.

(5)-2 Wireless LAN settings

This is the condition setting for connecting the GLT400 to a wireless LAN.

* This screen is not displayed unless the wireless unit is installed to the GLT400.

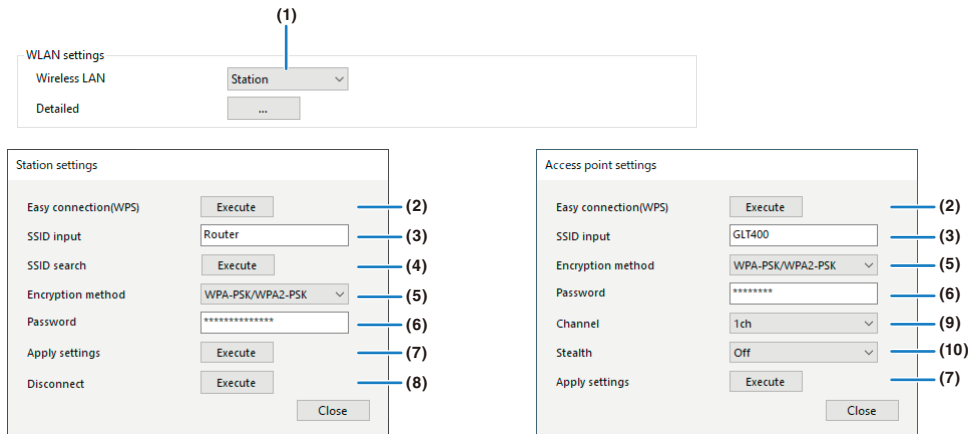

(1) Set up the wireless LAN.

After switching the wireless LAN, restart the wireless LAN.

If you cancel the restart of the wireless LAN, the wireless LAN is not switched.

Selection Item	Description
Off	Wireless LAN is not used.
Station	The GLT400 is set as the wireless LAN remote unit.
Access point	The GLT400 is set as the wireless LAN base unit.

CHECKPOINT

For the access point, you can set the settings only such as the FTP client, E-mail sending function, network time, etc.

When wireless LAN is used, wired LAN cannot be used.

Disconnect" -> "Wireless LAN restarting" -> "TCP-IP restarting" are executed.

(2) Easy Connection (WPS)

Easy Connection (WPS) is the standard for easily setting wireless LAN unit. Push button method is available. The name of WPS may vary depending on the commercially available wireless LAN router.

<Operation procedure> (Station)

Press "Execute" in the "Easy Connection (WPS)" screen. Then, the connection is completed by pressing the button corresponding to the WPS of the wireless LAN base unit to be connected.

<Operation procedure> (Access point)

Select the SSID of the device from the network list on the PC side and press the Connect button to go to the "Enter network security key" screen. After a while, the connection is established automatically. (Windows 10)

CHECKPOINT

Easy Connection (WPS) can also be performed by pressing the [FUNCTION] button on the GLT400.

When using the access point, it cannot be interrupted during Easy Connection (WPS) execution.

Detailed wireless LAN settings

Selection Item	Description
(3) SSID input	Station: Set the SSID (access point identification name) of the access point (base unit) to be connected. Access point: Set the SSID (access point identification name) of the GLT400. Up to 32 characters can be set with alphanumeric characters and symbols.
(4) SSID search	The list of wireless access points (base units) is displayed when the SSID is searched. When you select the access point (base unit) to connect from the list, it is displayed in the SSID input. (for Station only)
(5) Encryption method	Set the encryption. WEP: Set the WEP key with 10-digit alphanumeric symbols for WEP64 and 26-digit alphanumeric symbols for WEP128. WPA-PSK/WPA2-PSK: Set the password using 8 to 63 alphanumeric characters and symbols.
(6) WEP key password	It is displayed when the encryption is set. Set the key.
(7) Apply settings	Apply the encryption method, WEP key, and password settings.
(8) Connection	Connects or disconnects to/from the base unit. (for Station only)
(9) Channel	1ch to 13ch can be set. (for Access point only)
(10) Stealth	SSID concealment mode can be set. (for Access point only)

<Operation procedure> (when setting the Station)

- (1) Set the wireless LAN to "Station" and then restart the wireless LAN.
- (2) Set the SSID.
If you know the SSID of the wireless LAN base unit, enter the SSID.
You can also select from the list displayed when you search for the SSID.
- (3) Search for the SSID.
When the SSID is selected from the list, it is applied automatically.

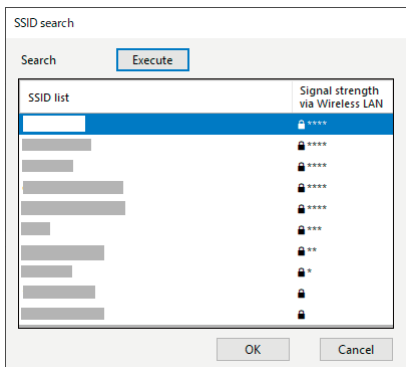

- (4) Set the encryption method.
WEP or WPA-PSK/WPA2-PSK can be set. If this setting is selected, the "WEP key" or "password" is displayed. Enter the one for the corresponding wireless LAN base unit.
- (5) After completing the above settings, press the "Execute" button to execute "Apply settings".
The settings are saved.
- (6) Execute "Connection" to enable the wireless.

<Operation procedure> (when setting the Access point)

- (1) Set the wireless LAN to "Access point" and then execute "Restart wireless LAN".
- (2) Set the SSID.
By default, the identification name generated by the GLT400 name and serial number is displayed.
- (3) Set the encryption method.
WEP or WPA-PSK/WPA2-PSK can be set. If this setting is selected, enter the "WEP key" or "password".
- (4) Set the channel.
Set the wireless LAN channel to be used from 1ch to 13ch. Generally, 1ch, 6ch, or 11ch is set.

(5) Set the stealth.

When this is set, the SSID cannot be searched from other terminals. Enter the SSID name directly on the device to be connected.

(6) After completing the above settings, press the "Execute" button to execute "Apply settings". The settings are saved.

(5)-3 TCP-IP settings

This is the setting for connecting the GLT400 via TCP/IP.

In the Access point, only the IP address, port number and non-communication disconnection can be set.

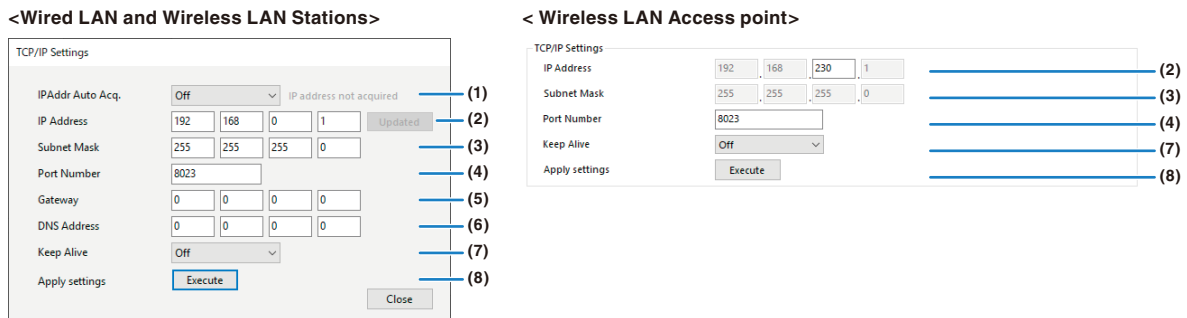

Selection item	Description
(1) IP Address Auto Acquisition	Set whether the IP address should be manually set or automatically acquired. * If auto acquisition is enabled, the auto acquisition operation (performed when the power is turned on or the settings are reflected) may take a few seconds to around one minute.
(2) IP Address	Sets the IP address of the GLT400. (0-255.0-255.0-255.0-255)
(3) Subnet Mask	Sets the subnet mask of the GLT400. (0-255.0-255.0-255.0-255)
(4) Port Number	Sets the IP port number of the GLT400 (1024-65535).
(5) Gateway	Sets the gateway address of the GLT400. (0-255.0-255.0-255.0-255)
(6) DNS Address	Sets the DNS address of the GLT400. (0-255.0-255.0-255.0-255)
(7) Keep Alive	Used to set the function to detect the non-communication time and automatically disconnect the socket connection. For details, refer to "Keep Alive".
(8) Reflect Settings	Reflects the TCP-IP settings immediately (without turning off and on the power). * Connections are forcibly disconnected when the settings are reflected. * Reflecting the settings may take a few seconds to around one minute.

CAUTION

During IP Address Auto Acquisition, the LAN LED (when wired LAN is used) or SD ACCESS LED (when wireless LAN is used) flashes at 1-second intervals. If the flashing does not disappear, the IP address has not been acquired properly. Set "IP Address Auto Acquisition" to "Not used" and then set the IP address manually.

When the wired LAN setting was changed, turn the power off and then on again, or apply the settings. (The socket connection is forcibly disconnected.)

When you want to use the IP Address Auto Acquisition function, the DHCP server must be operating separately within the searchable network.

Keep Alive

Detects no-communication time and automatically disconnects the socket connection.

Selection item	Description
OFF	Disconnection is not performed.
10 seconds to 1 hour	Disconnects the socket connection if no-communication status continues longer than the specified time. Generate some kind of communication within the setting time. Note that, while the supplied application software is used, no-communication status continues during the replay of captured data. (This function is effective only for the command port. The Web server function or FTP server function is not influenced.)

(5)-4 Other settings

Set other network settings.

Identification name

This is a name to identify the GLT400. It is also used to identify by the supplied application software. By default, GLT4_<9-digit serial number of the GLT400> has been set.

* This Identification name is not a general computer name (NETBIOS name) or DNS name.

New Line Code

Set the New Line Code used when controlling with the I/F command.

Selection item	Description
CR+LF	End the line with CR/LF.
LF	End the line with LF.
CR	End the line with CR.

FTP Client Settings

Set the backup destination FTP server.

	Description
(1) Easy FTP Client settings	The default FTP connection destination can be easily set. (Manual setting, GRM-ONE BASIC)
(2) FTP Server	Enter the domain name or IP address of the FTP server. (Up to 127 characters)
(3) User name	Enter the user name of FTP account. (Up to 31 characters)
(4) Password	Enter the password of FTP account. (Up to 31 characters)
(5) Port Number	Enter the port number used for FTP. (0 to 65535) Set the following according to the encryption method. Off: 21 Explicit: 21 Implicit: 990
(6) PASV mode	Set the PASV mode. On (Set when communicating with an external FTP server in a firewall environment.) Off (Set when communicating with the FTP server in a normal network environment.)
(7) Encryption method	Encrypts the data sent and received with FTP. Off: Not encrypted. Explicit: Explicit mode. Encryption is started after the connection. Implicit: Implicit mode. Encrypted communication is started from the time when connected.
(8) Recorded file when backup is successful	When the backup to the FTP server is successful, select "Leave" or "Delete" the captured files. By selecting the "Delete", the SD CARD is not full. Therefore, you can capture for a long time.
(9) Apply settings	The settings are applied to the GLT400.
(10) FTP Server Connection Test	Execute (Test the connection to the FTP server. When the connection test is completed, the message is displayed. If the connection is disabled, check the settings and try the connection test again.

FTP Server Settings

Set the settings to make the GLT400 function as an FTP server.

If you want to connect with FTP over TLS with your own digital signature certificate/encryption certificate, please contact us.

	Description
(1) Anonymous access	Set whether to allow anonymous access. Disable: Anonymous access is not allowed. Enable: Anonymous access is allowed.
(2) User name	Enter the user name of the FTP account. (up to 31 characters) User name is "GLT400" by default.
(3) Password	Enter the password of the FTP account. (up to 31 characters) Password is "GLT400" by default.
(4) Port Number	Enter the port number used for the FTP. Usually the port number is 21. (0 to 65535)
(5) Encryption method	The data sent and received is encrypted in the FTP server. Off: Not encrypted. Off/ Explicit encryption (Explicit): Explicit mode. Encryption is started after the connection. If encryption is not activated, connect with encryption Off. Explicit encryption (Explicit): Explicit mode. Encryption is started after the connection. Implicit encryption (Implicit): Implicit mode. Encrypted communication is performed from the time when connected.
(6) Apply settings	The settings are applied to the GLT400.



When your own digital signature certificate has not been installed, a self-signed certificate is output. Please use it after acknowledging.

WEB Server Settings

Set the settings to make the GLT400 function as a WEB server.

If you want to connect with HTTPS with your own digital signature certificate/encryption certificate, please contact us.

	Description
(1) Port Number	Enter the port number used for the WEB server. Usually the port number is 80. (0 to 65535)
(2) Basic authentication	When connecting to the WEB server, you can restrict it by user name and password. Off: Basic authentication is disabled. On: Basic authentication is enabled. The access is restricted with user name and password.
(3) User name	Enter the user name of basic authentication. (Up to 31 characters) User name is "GLT400" by default.
(4) Password	Enter the password of basic authentication. (Up to 31 characters) Password is "GLT400" by default.
(5) Encryption (https)	The communication information is encrypted in the WEB server. By default, the connection is established with the self-signed certificate installed in advance, so some warnings may be displayed. If you want to use your own certificate, please contact us.
(6) Apply settings	The settings are applied to the GLT400.

CHECKPOINT

When your own digital signature certificate has not been installed, a self-signed certificate is output. Please use it after acknowledging.

E-mail send setting

Set the settings for sending e-mail from the GLT400.

If e-mail send setting is set, the notification settings (Alarm, Low communication speed, Recording destination free space) are sent. Also, if periodic notification is set, it is sent at the set time.

	Description
(1) To	Set the E-mail address of the E-mail destination. (Up to 63 characters)
(2) CC1 to CC3	Up to 3 E-mail addresses can be set in CC. (Up to 63 characters)
(3) Subject	The subject of the E-mail can be registered by entering it in the character string. (Up to 63 characters)
(4) Alarm	When set to On, the occurrence of an alarm is notified.
(5) Low signal strength	When set to On, the information of low signal strength is notified.
(6) Recording destination free space	When set to On, the information of recording destination free space is notified.
(7) Periodic notifications	Captured information can be sent periodically. Set the sending interval or the sending time.

Outgoing mail server settings

The Outgoing mail server settings can be set from the GLT400.

	Description
(1) Easy send mail settings	Specified SMTP server can be set. (Manual setting, Gmail, Office365)
(2) Send (SMTP) Server Name	Set the E-mail destination server name. (Up to 63 characters)
(3) SMTP port number	Set from 0 to 65535. Generally, set the following settings: SMTP encryption is Off: 25 SMTP encryption is StartTLS: 587 SMTP encryption is SSL: 465
(4) Time zone	Set the time zone of the area where the GLT400 is used. (UTC+9:00 in Japan)
(5) SMTP encryption	Set the SMTP encryption. (Off, StartTLS, SSL)
(6) SMTP-AUTH	Set the SMTP-AUTH authentication method. (Off, PLAIN, LOGIN, CRAM-MD5, DIGEST-MD5)
(7) SMTP user name	Set the user name for SMTP authentication. (Up to 63 characters)
(8) SMTP password	Set the password for SMTP authentication. (Up to 31 characters)
(9) E-mail address	Set an E-mail address (up to 63 characters)
(10) Test email	Executes the E-mail sending test.

Internet Time Setting

The clock of the GLT400 can be adjusted automatically via the Internet.

	Description
(1) Internet Time	Set whether to use this function. Off: This function is not used. The time is not adjusted. On: This function is used to adjust the time.
(2) NTP Server	Enter the domain name of the NTP Server to be used.
(3) Time Zone	Set the time zone of the area where the GLT400 is used. (UTC+9:00 in Japan)
(4) Synchronized Time	Set the time to be synchronized with the NTP Server. When the set time is reached, the time is synchronized by the method set in the synchronized time.
(5) Adjust Mode	Synchronize immediately/Synchronize gradually Set the method to synchronize with the NTP Server. Synchronize immediately: When the set time is reached, the GLT400 immediately adjusts to the time on the NTP Server. Synchronize gradually: Even when the set time is reached, the time is not synchronized immediately. The time is gradually synchronized with the time on the NTP Server. The adjustment time is approx. 43 seconds per day. (approx. 10 ms per 20 seconds.)
(6) Connection Test	Test the connection to the NTP Server. When the connection test is completed, the message is displayed. If the NTP Server cannot be connected, check the settings and then try the connection test again.

CAUTION

If the error with the NTP Server is within 500 ms, the time is not synchronized.

(6) OTHER settings

Various conditions can be set.

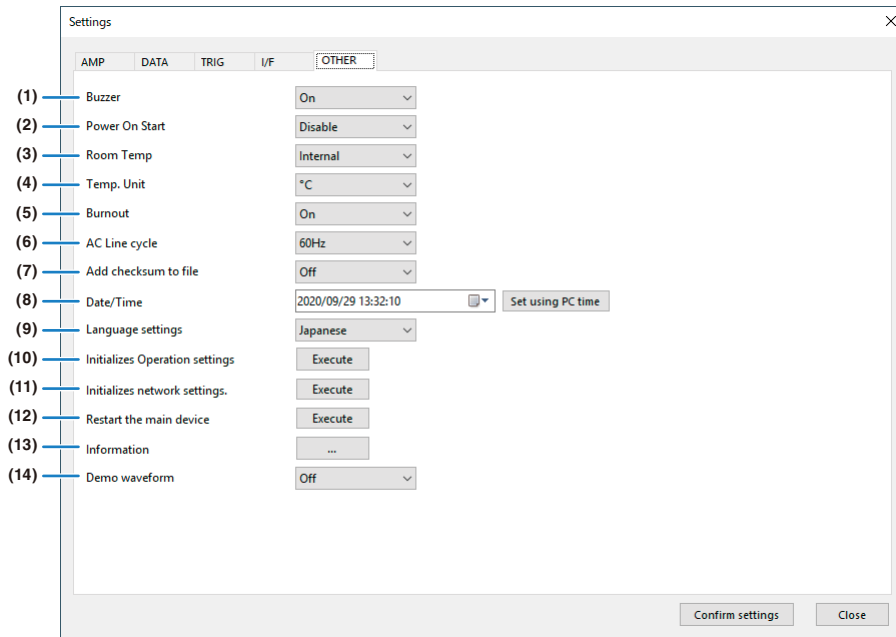

Selection Item	Description	
(1) Buzzer	On, Off	
(2) Power On Start	Disable, Enable	
(3) Room Tem	Internal, External	
(4) Tem. Unit	,	
(5) Burnout	Off, On	
(6) AC Line cycle	50Hz, 60Hz	
(7) Add checksum to file	Off, On	
(8) Date/Time	Date	2005 January 1 to 2035 December 31
	Time	0:0:0 to 23:59:59
(9) Language setting	Japanese, English(US), English(UK), French, German, Chinese, Korean, Russian, Spanish	
(10) Initializes operation settings	▷ Execute	
(11) Initializes network settings	▷ Execute	
(12) Restart the main device	▷ Execute	
(13) Information	▷ Display information	
(14) Demo waveform	Off, On	

(6)-1 Buzzer

Set the Buzzer to On or Off.

(6)-2 Power On Start

Sets the feature which initiates measurement as soon as the GLT400 is turned on.

Selection item	Description
Disable	When turning On the power, the capture is started automatically.
Enable	Even when turning On the power, the capture is not started automatically.

(6)-3 Room temperature compensation

Selection item	Description
Internal	The room temperature compensation in the GLT400 is enabled. (Please usually select the "Internal".)
External	This is used to execute the room temperature compensation through external device.

(6)-4 Temp. Unit

Toggles the temperature unit between °C (Centigrade) and °F (Fahrenheit) for temperature settings.

When °F (Fahrenheit) is selected, calculation is performed using the following formula:

$$^{\circ}\text{F (Fahrenheit)} = ^{\circ}\text{C (Centigrade)} \times 1.8 + 32$$

Calculate the accuracy as: Centigrade accuracy \times 1.8.

(6)-5 Burnout

Sets a feature which checks sensor burnout in a thermocouple.

Selection item	Description
Off	Burnout check is disabled.
On	Periodical burnout check is conducted.

 CAUTION

During a burnout check, voltage is applied to the GLT400. Therefore, set Burnout to "Off" when GLT400 is connected in parallel with other devices to avoid any effect from these voltages.

(6)-6 AC Line Frequency

Select the frequency of the AC line to be used.

Selection item	Description
50Hz	For an area with a power supply frequency of 50 Hz
60Hz	For an area with a power supply frequency of 60Hz

 CAUTION

In this setting, select a frequency for noise removal using the digital filter.

Note that no noise in the power supply can be removed if this setting is wrong.

For the the sampling speed where the GLT400's digital filter becomes effective, refer to "(3)-1 Sampling interval".

(6)-7 Add checksum to file

The checksum is used to check the consistency of the data file.

If the contents of the file are changed, checksum confirmation does not match the checksum, so you can see that the file was changed.

The checksum function adds a checksum to the data file.

Selection item	Description
Off	The checksum is added to the data file.
On	The checksum is not added to the data file.

* The checksum is also added to the backup file, ring / relay file, data save file.
Use the GL-Connection software on the PC to check the checksum.

CAUTION

The checksum is available only for GBD format.

If the captured file converted and saved using a device other than this GLT400 (GL-Connection), the checksums does not match

(6)-8 Date/Time

Makes settings related to the GLT400 clock.

The internal clock (date and time) of the GLT400 can be set.

(6)-9 Language setting

Set the desired language from 9 languages (Japanese, English (US), English (UK), French, German, Chinese, Korean, Russian and Spanish).

The language used in CSV capturing file and Web server function is changed.

(6)-10 Initializes operation settings

Initializes the operation settings. After initialization, the setting conditions returns to the factory default settings.

For the initialization information, refer to “3.5 Description of Operation Mode (7) Initialize and read settings”.

(6)-11 Initializes network settings

Initializes the network settings. After initialization, the setting conditions returns to the factory default settings.

For the initialization information, refer to “3.5 Description of Operation Mode (7) Initialize and read settings”.

(6)-12 Restart the GLT400

The GLT400 is forcibly restarted. Capturing must be stopped in advance. When connecting to the network, the network is also disconnected. Reconnect after restarting the GLT400.

(6)-13 Information

Displays system information.

(6)-14 Demo Waveform Mode

The demo waveform is displayed without inputting an analog signal. To check the data, use the monitor window, WEB server function or GL-Connection software on the PC.

Selection item	Description
Off	The demo waveform is not displayed.
On	The demo waveform is displayed.

4.4 File Operations Screen

You can view the status of the internal memory in the GLT400 and the status of the SD CARD, and download the file to the PC.

This screen is available only in STAND-ALONE mode.

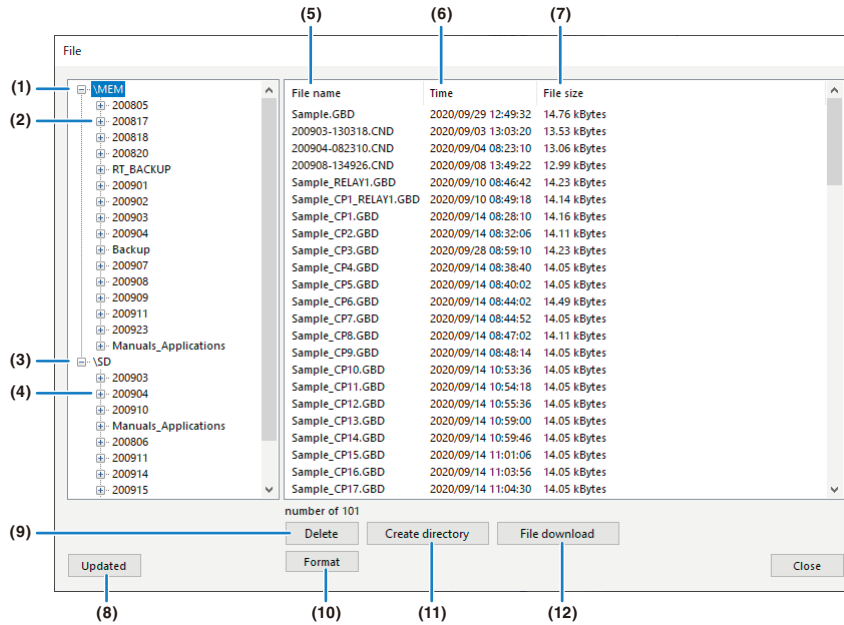

Selection Item	Description
(1) Internal memory	Displays the internal memory. When selecting it, the files are displayed on the right side. To expand the folder, press the [+] button.
(2) Folder in internal memory	Displays the folders in the internal memory. When selecting it, the files are displayed on the right side.
(3) SD CARD	Displays the SD CARD. When selecting it, the files are displayed on the right side. To expand the folder, press the [+] button.
(4) Folder in SD CARD	Displays the folders in the SD CARD. When selecting it, the files are displayed on the right side.
(5) File name	Displays the file name.
(6) Time	Displays the time of the file.
(7) File size	Displays the file size.
(8) Update	Updates the screen display.
(9) Delete	Deletes the selected files. When a folder is selected, the folder can be deleted.
(10) Format	Format the internal memory or SD CARD. Please note that everything is erased.
(11) Create directory	The folder is created on the displayed path.
(12) File download	Downloads the selected files to the PC. Multiple files can be selected with the CTRL key or SHIFT key.

4.5 Monitor Screen

The digital value of the GLT400 input signal, capturing status, capturing control, alarm display, alarm clear, pulse clear and error description can be checked.

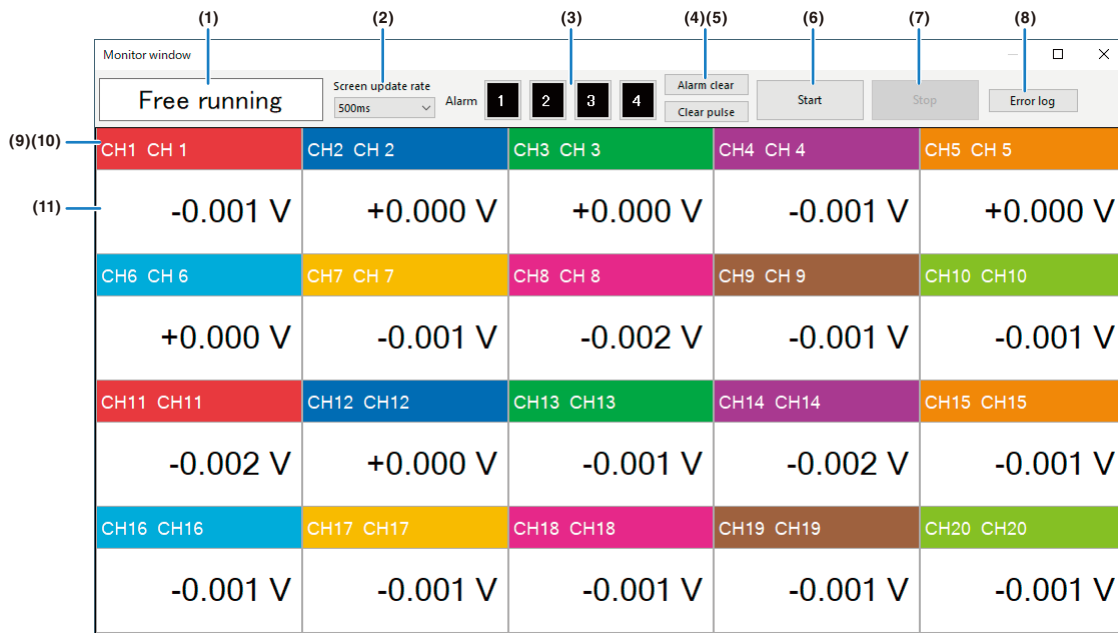

Selection Item	Description																		
(1) Status	Displays the capturing status of the GLT400. <table border="1"> <thead> <tr> <th>Item</th> <th>Description</th> </tr> </thead> <tbody> <tr> <td>Free running</td> <td>Displayed when the power is turned on or capturing is not performed.</td> </tr> <tr> <td>Waiting for trigger</td> <td>Displayed when waiting for the trigger establishment after the measurement starts.</td> </tr> <tr> <td>Trigger detection</td> <td>Displayed when the trigger is established.</td> </tr> <tr> <td>Capturing in internal memory</td> <td>Displayed when data is being captured in the internal memory.</td> </tr> <tr> <td>Capturing in SD CARD</td> <td>Displayed when data is being captured in the SD CARD.</td> </tr> <tr> <td>Capturing stop</td> <td>Displayed when capturing is stopped.</td> </tr> <tr> <td>Data capturing finished</td> <td>Displayed when data capturing is finished and waiting for capturing stop.</td> </tr> <tr> <td>Writing</td> <td>Displayed when capturing stop process is being executed.</td> </tr> </tbody> </table>	Item	Description	Free running	Displayed when the power is turned on or capturing is not performed.	Waiting for trigger	Displayed when waiting for the trigger establishment after the measurement starts.	Trigger detection	Displayed when the trigger is established.	Capturing in internal memory	Displayed when data is being captured in the internal memory.	Capturing in SD CARD	Displayed when data is being captured in the SD CARD.	Capturing stop	Displayed when capturing is stopped.	Data capturing finished	Displayed when data capturing is finished and waiting for capturing stop.	Writing	Displayed when capturing stop process is being executed.
Item	Description																		
Free running	Displayed when the power is turned on or capturing is not performed.																		
Waiting for trigger	Displayed when waiting for the trigger establishment after the measurement starts.																		
Trigger detection	Displayed when the trigger is established.																		
Capturing in internal memory	Displayed when data is being captured in the internal memory.																		
Capturing in SD CARD	Displayed when data is being captured in the SD CARD.																		
Capturing stop	Displayed when capturing is stopped.																		
Data capturing finished	Displayed when data capturing is finished and waiting for capturing stop.																		
Writing	Displayed when capturing stop process is being executed.																		
(2) Screen update rate	Set the screen update rate. 500 ms, 1 s, 2 s, 5 s, 10 s It is not linked to the sampling interval. When the sampling interval is 1 sec, the same data will be acquired at 2 points even if the update rate is set to 500ms.																		
(3) Alarm	Displays the alarm output status. The number where the alarm is output is displayed in red.																		
(4) Alarm clear	The output alarm is cleared. It is activated only when "Hold alarm" is enabled.																		
(5) Clear pulse	The accumulated value of the pulse is cleared. This is enabled only when the pulse input is set to Accumulation.																		
(6) Capturing start	Capturing is started.																		
(7) Capturing stop	Capturing is stopped.																		
(8) Error log	Displays the error log.																		
(9) CH number	Displays the CH number of the input signal.																		
(10) Annotation	Displays the annotation string of the input signal.																		
(11) Measurement value	Displays the measured value.																		

4.6 Save / Load Current Settings Screen

The settings of the GLT400 and the network are saved and loaded. The save destination is the internal memory of the GLT400 or the SD CARD.

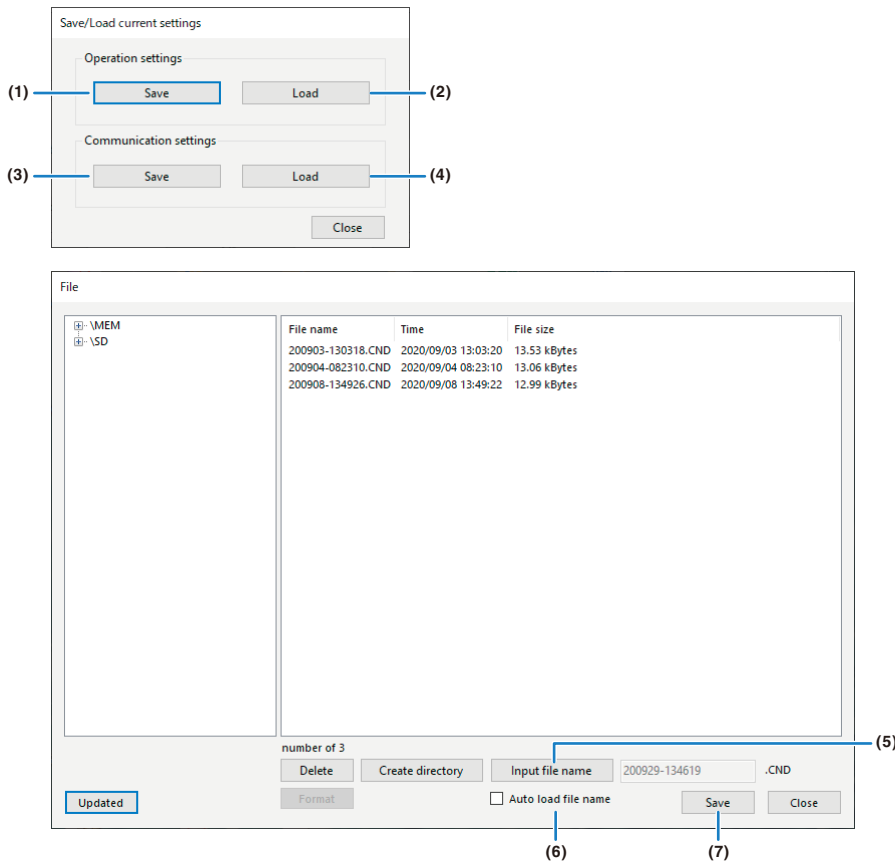

Selection Item	Description
(1) Save operation settings	Saves the operation settings of the GLT400 in the internal memory of the GLT400 or the SD CARD. For the description of the items, refer to “3.5 Description of Operation Mode (7) Initialize and read settings”. The extension of the operation setting file is *.CND.
(2) Load operation settings	By loading the file saved in Save operation settings, the settings saved in the file is restored.
(3) Save communication settings	Saves the communication settings of the GLT400 in the internal memory of the GLT400 or the SD CARD. For the description of the items, refer to “3.5 Description of Operation Mode (7) Initialize and read settings”. The extension of the communication setting file is *.NCD.
(4) Load communication settings	By loading the file saved in Saving communication settings, the settings saved in the file is restored. If the communication setting file is loaded, the current communication cannot be maintained, so the communication is forcibly disconnected.
(5) Input file name	Enter the file name of the saved file.
(6) Auto load file name	Auto load file can be saved in SD CARD only. When the auto load file is saved in the root folder of the SD CARD, the set file is automatically loaded and the settings are applied when the GLT400 is started.
(7) Save	Save the set file

CHAPTER 5 Specifications

This chapter describes the basic specifications for the GLT400.

PRODUCT SUMMARY

5.1 Standard Specifications

5.2 Function Specifications

5.3 List of Error Codes

5.4 Accessories / Optional Accessories

5.5 External Dimensions

5.1 Standard Specifications

Standard specifications (GLT400)

Item		Description																										
Number of analog terminal units installed		Up to 10 units (200CH)																										
Analog terminal unit type		<ul style="list-style-type: none"> • Standard terminal • Withstand high-voltage high-precision terminal • Screwless terminal 																										
Backup function		Setting conditions: EEPROM / Clock: Lithium secondary battery																										
Clock accuracy (23°C environment)		±0.002% (approx. 50 seconds per month)																										
Operating environment		-20 to 60°C (Supplied AC adapter: 0 to 45°C), 5 to 85% RH (If a USB PD is used as the power supply, it depends on the power supply specifications.)																										
Withstand voltage	Standard terminal/ Screwless terminal	Between input channel and GND terminal: 350Vp-p 1 minute Between input terminals: 350 Vp-p 1 minute																										
	Withstand high-voltage high-precision terminal	Between input channel and GND terminal: 2300VACrms 1 minute Between input terminals: 600 Vp-p																										
Power supply		<ul style="list-style-type: none"> • AC adapter: 100 to 240V AC / 50 to 60 Hz • DC input: 8.5 to 24V DC (maximum 26.4V) • USB power supply: USB PD compatible, external USB PD compatible battery 																										
Power consumption		AC power consumption (when using the supplied AC adapter) <table border="1" data-bbox="619 947 1075 1048"> <thead> <tr> <th>No.</th> <th>Power supply</th> <th>Normal</th> </tr> </thead> <tbody> <tr> <td rowspan="2">1</td> <td>AC100V</td> <td>24 VA</td> </tr> <tr> <td>AC240V</td> <td>35 VA</td> </tr> </tbody> </table> DC current consumption <table border="1" data-bbox="619 1104 1075 1335"> <thead> <tr> <th>No.</th> <th>DC voltage</th> <th>Normal</th> </tr> </thead> <tbody> <tr> <td>1</td> <td rowspan="2">+24V</td> <td>0.36 A</td> </tr> <tr> <td>2</td> <td>0.27 A</td> </tr> <tr> <td>3</td> <td rowspan="2">+12V</td> <td>0.70 A</td> </tr> <tr> <td>4</td> <td>0.50 A</td> </tr> <tr> <td>5</td> <td rowspan="2">+8.5V</td> <td>1.00 A</td> </tr> <tr> <td>6</td> <td>0.70 A</td> </tr> </tbody> </table>	No.	Power supply	Normal	1	AC100V	24 VA	AC240V	35 VA	No.	DC voltage	Normal	1	+24V	0.36 A	2	0.27 A	3	+12V	0.70 A	4	0.50 A	5	+8.5V	1.00 A	6	0.70 A
No.	Power supply	Normal																										
1	AC100V	24 VA																										
	AC240V	35 VA																										
No.	DC voltage	Normal																										
1	+24V	0.36 A																										
2		0.27 A																										
3	+12V	0.70 A																										
4		0.50 A																										
5	+8.5V	1.00 A																										
6		0.70 A																										
External dimensions (approx.) [W x D x H] (GLT400 + terminal installed)	Standard terminal	187.5 × 183 × 65.5 mm (excluding protrusions)																										
	Withstand high-voltage high-precision terminal	187.5 × 183 × 73.4 mm (excluding protrusions)																										
	Screwless terminal	187.5 × 183 × 65.5 mm (excluding protrusions)																										
Weight (approx.) *1 (Main unit + terminal installed)	Withstand high-voltage high-precision terminal	1090 g																										
	Others	1120 g																										
	Screwless terminal	1020 g																										
Others		Vibration proof: Automobile parts Type 1 Class A equivalent Buzzer (Key, etc.)																										

*1: AC adapter not included.

Power supply function (USB Power Delivery)

Item	Description
Rated voltage	6 V
Standard	Compliant with USB Power Delivery 2.0
Available power supply unit	Standards: Compliant with USB Power Delivery 2.0 or later Output: 5V 2A (10W)

Memory devices

Item	Description
Memory capacity	Internal memory: approx. 4 GB SD CARD slot: 1 (Compatible with SDHC, up to approx. 32GByte memory available) * Possible to save up to 2 GByte for one file
Memory contents	<ul style="list-style-type: none"> • Setup conditions • Measured data

PC I/F

Item	Description
Interface types	Ethernet (10BASE-T/100BASE-TX) USB 2.0 Wireless LAN (Option)
Functions	Data transfer to the PC (Real-time, Internal memory or SD CARD) PC control of the GLT400 Connect to network as a remote unit of GL840
Ethernet functions (10BASE-T/100BASE-TX)	Web server functions: Displays the screen images and GLT400 operations FTP server function: Transfer and delete the captured files in the internal memory or SD CARD. FTP client function: Back up the captured data to the FTP server NTP client function: Time-synchronize the NTP server DHCP client function: IP Address Auto Acquisition DHCP client function: Automatically retrieves the IP address (Wireless LAN/Base unit mode) Modbus/TCP communication
USB functions	USB drive mode: Transfer and delete the captured files in the internal memory or SD CARD
Realtime data transfer speed *1	10 msec/1 ch maximum

*1: The transfer speed depends on the number of channels.

Standard terminal B-564/Screwless terminal B-564SL

Item		Description																																																																	
Number of input channels	Standard terminal	20 channels (up to 10 units (200 channels) can be connected to GLT400) * Between GLT400 and terminal and between terminals can be direct-connected or with an expansion terminal connection cable (sold separately).																																																																	
	Screwless terminal	20 channels (up to 10 units (200 channels) can be connected to GLT400) * Between GLT400 and terminal and between terminals can be direct-connected or with an expansion terminal connection cable (sold separately).																																																																	
Input terminal type	Standard terminal	M3 screw type terminals (Rectangular flat washer)																																																																	
	Screwless terminal	Screwless terminal																																																																	
Input method	Photo MOS relay scanning system All channels isolated, balanced input * Terminal b to be used to connect the Resistance bulb is shorted within all channels.																																																																		
Scan speed	10 ms/1 ch maximum																																																																		
Measurement ranges	Voltage: 20, 50, 100, 200, 500 mV; 1, 2, 5, 10, 20, 50, 100 V; 1-5 V F.S. Temperature Thermocouples: K, J, E, T, R, S, B, N, C (WRe5-26) Resistance bulb: Pt100, JPt100, Pt1000 (IEC751) Temperature range: 100°C, 500°C, 2000°C (In the case of Fahrenheit: 150°F, 750°F, 3000°F) Humidity: 0 to 100% (voltage 0 to 1 V scaling conversion) fixed																																																																		
Measurement accuracy (23°C ±5°C) • When 30 minutes or more have elapsed after power was switched on • Sampling 1 s/20 ch • Filter ON (10) • GND connected	Voltage: 0.1% of F.S. Temperature ● Thermocouple																																																																		
	<table border="1"> <thead> <tr> <th>Thermocouple</th> <th>Measurement Temperature Range (°C)</th> <th>Measurement Accuracy</th> </tr> </thead> <tbody> <tr> <td rowspan="4">R/S</td> <td>0 ≤ TS ≤ 100</td> <td>±5.2</td> </tr> <tr> <td>100 < TS ≤ 300</td> <td>±3.0</td> </tr> <tr> <td>R : 300 < TS ≤ 1600</td> <td>± (0.05% of rdg +2.0)</td> </tr> <tr> <td>S : 300 < TS ≤ 1760</td> <td>± (0.05% of rdg +2.0)</td> </tr> <tr> <td rowspan="2">B</td> <td>400 ≤ TS ≤ 600</td> <td>±3.5</td> </tr> <tr> <td>600 < TS ≤ 1820</td> <td>± (0.05% of rdg +2.0)</td> </tr> <tr> <td rowspan="2">K</td> <td>-200 ≤ TS ≤ -100</td> <td>± (0.05% of rdg +2.0)</td> </tr> <tr> <td>-100 < TS ≤ 1370</td> <td>± (0.05% of rdg +1.0)</td> </tr> <tr> <td rowspan="2">E</td> <td>-200 ≤ TS ≤ -100</td> <td>± (0.05% of rdg +2.0)</td> </tr> <tr> <td>-100 < TS ≤ 800</td> <td>± (0.05% of rdg +1.0)</td> </tr> <tr> <td rowspan="2">T</td> <td>-200 ≤ TS ≤ -100</td> <td>± (0.1% of rdg +1.5)</td> </tr> <tr> <td>-100 < TS ≤ 400</td> <td>± (0.1% of rdg +0.5)</td> </tr> <tr> <td rowspan="3">J</td> <td>-200 ≤ TS ≤ -100</td> <td>±2.7</td> </tr> <tr> <td>-100 < TS ≤ 100</td> <td>±1.7</td> </tr> <tr> <td>100 < TS ≤ 1100</td> <td>± (0.05% of rdg +1.0)</td> </tr> <tr> <td rowspan="2">N</td> <td>-200 ≤ TS < 0</td> <td>± (0.1% of rdg +2.0)</td> </tr> <tr> <td>0 ≤ TS ≤ 1300</td> <td>± (0.1% of rdg +1.0)</td> </tr> <tr> <td>C (W)</td> <td>0 ≤ TS ≤ 2000</td> <td>± (0.1% of rdg +1.5)</td> </tr> <tr> <td colspan="2">Reference contact compensation accuracy</td> <td>±0.5</td> </tr> </tbody> </table> <p>* Thermocouple diameters T - K: 0.32 , others: 0.65</p> <p>● Resistance bulb</p> <table border="1"> <thead> <tr> <th>Type</th> <th>Measurement Temperature Range (°C)</th> <th>Applied current</th> <th>Measurement Accuracy</th> </tr> </thead> <tbody> <tr> <td>Pt100</td> <td>-200 to 850 (FS=1050)</td> <td>1 mA</td> <td>±1.0</td> </tr> <tr> <td>JPt100</td> <td>-200 to 500 (FS=700)</td> <td>1 mA</td> <td>±0.8</td> </tr> <tr> <td>Pt1000</td> <td>-200 to 500 (FS=700)</td> <td>0.3 mA</td> <td>±0.8</td> </tr> </tbody> </table> <p>* 3-wire system</p>		Thermocouple	Measurement Temperature Range (°C)	Measurement Accuracy	R/S	0 ≤ TS ≤ 100	±5.2	100 < TS ≤ 300	±3.0	R : 300 < TS ≤ 1600	± (0.05% of rdg +2.0)	S : 300 < TS ≤ 1760	± (0.05% of rdg +2.0)	B	400 ≤ TS ≤ 600	±3.5	600 < TS ≤ 1820	± (0.05% of rdg +2.0)	K	-200 ≤ TS ≤ -100	± (0.05% of rdg +2.0)	-100 < TS ≤ 1370	± (0.05% of rdg +1.0)	E	-200 ≤ TS ≤ -100	± (0.05% of rdg +2.0)	-100 < TS ≤ 800	± (0.05% of rdg +1.0)	T	-200 ≤ TS ≤ -100	± (0.1% of rdg +1.5)	-100 < TS ≤ 400	± (0.1% of rdg +0.5)	J	-200 ≤ TS ≤ -100	±2.7	-100 < TS ≤ 100	±1.7	100 < TS ≤ 1100	± (0.05% of rdg +1.0)	N	-200 ≤ TS < 0	± (0.1% of rdg +2.0)	0 ≤ TS ≤ 1300	± (0.1% of rdg +1.0)	C (W)	0 ≤ TS ≤ 2000	± (0.1% of rdg +1.5)	Reference contact compensation accuracy		±0.5	Type	Measurement Temperature Range (°C)	Applied current	Measurement Accuracy	Pt100	-200 to 850 (FS=1050)	1 mA	±1.0	JPt100	-200 to 500 (FS=700)	1 mA	±0.8	Pt1000	-200 to 500 (FS=700)	0.3 mA
Thermocouple	Measurement Temperature Range (°C)	Measurement Accuracy																																																																	
R/S	0 ≤ TS ≤ 100	±5.2																																																																	
	100 < TS ≤ 300	±3.0																																																																	
	R : 300 < TS ≤ 1600	± (0.05% of rdg +2.0)																																																																	
	S : 300 < TS ≤ 1760	± (0.05% of rdg +2.0)																																																																	
B	400 ≤ TS ≤ 600	±3.5																																																																	
	600 < TS ≤ 1820	± (0.05% of rdg +2.0)																																																																	
K	-200 ≤ TS ≤ -100	± (0.05% of rdg +2.0)																																																																	
	-100 < TS ≤ 1370	± (0.05% of rdg +1.0)																																																																	
E	-200 ≤ TS ≤ -100	± (0.05% of rdg +2.0)																																																																	
	-100 < TS ≤ 800	± (0.05% of rdg +1.0)																																																																	
T	-200 ≤ TS ≤ -100	± (0.1% of rdg +1.5)																																																																	
	-100 < TS ≤ 400	± (0.1% of rdg +0.5)																																																																	
J	-200 ≤ TS ≤ -100	±2.7																																																																	
	-100 < TS ≤ 100	±1.7																																																																	
	100 < TS ≤ 1100	± (0.05% of rdg +1.0)																																																																	
N	-200 ≤ TS < 0	± (0.1% of rdg +2.0)																																																																	
	0 ≤ TS ≤ 1300	± (0.1% of rdg +1.0)																																																																	
C (W)	0 ≤ TS ≤ 2000	± (0.1% of rdg +1.5)																																																																	
Reference contact compensation accuracy		±0.5																																																																	
Type	Measurement Temperature Range (°C)	Applied current	Measurement Accuracy																																																																
Pt100	-200 to 850 (FS=1050)	1 mA	±1.0																																																																
JPt100	-200 to 500 (FS=700)	1 mA	±0.8																																																																
Pt1000	-200 to 500 (FS=700)	0.3 mA	±0.8																																																																

Item	Description																																																						
	<p>● Temperature range</p> <table border="1" style="width: 100%; border-collapse: collapse;"> <thead> <tr> <th style="background-color: #d9e1f2;">Type</th> <th style="background-color: #d9e1f2;">Temperature range</th> <th style="background-color: #d9e1f2;">Resolution</th> <th style="background-color: #d9e1f2;">Measurement Range</th> </tr> </thead> <tbody> <tr> <td rowspan="3" style="text-align: center;">R/S</td> <td>100 F.S.</td> <td>0.01</td> <td>0 to 100</td> </tr> <tr> <td>500 F.S.</td> <td>0.05</td> <td>0 to 500</td> </tr> <tr> <td>2000 F.S.</td> <td>0.1</td> <td>R : 0 to 1600 S : 0 to 1760</td> </tr> <tr> <td rowspan="2" style="text-align: center;">B</td> <td>500 F.S.</td> <td>0.05</td> <td>400 to 500</td> </tr> <tr> <td>2000 F.S.</td> <td>0.1</td> <td>500 to 1820</td> </tr> <tr> <td rowspan="4" style="text-align: center;">K/E/T/J/N</td> <td>100 F.S.</td> <td>0.01</td> <td>-100 to 100</td> </tr> <tr> <td rowspan="2">500 F.S.</td> <td rowspan="2">0.05</td> <td>K/E/J/N : -200 to 500</td> </tr> <tr> <td>T : -200 to 400</td> </tr> <tr> <td rowspan="2">2000 F.S.</td> <td rowspan="2">0.1</td> <td>K : -200 to 1370</td> </tr> <tr> <td>E : -200 to 800 T : -200 to 400 J : -200 to 1100 N : -200 to 2000</td> </tr> <tr> <td rowspan="3" style="text-align: center;">C (W)</td> <td>100 F.S.</td> <td>0.01</td> <td>0 to 100</td> </tr> <tr> <td>500 F.S.</td> <td>0.05</td> <td>0 to 500</td> </tr> <tr> <td>2000 F.S.</td> <td>0.1</td> <td>0 to 2000</td> </tr> <tr> <td rowspan="4" style="text-align: center;">Pt</td> <td>100 F.S.</td> <td>0.01</td> <td>-100 to 100</td> </tr> <tr> <td>500 F.S.</td> <td>0.05</td> <td>-200 to 500</td> </tr> <tr> <td rowspan="2">2000 F.S.</td> <td rowspan="2">0.1</td> <td>Pt100 : -200 to 850</td> </tr> <tr> <td>JPt100/Pt1000 : -200 to 500</td> </tr> </tbody> </table> <p>* Measurement accuracy does not change due to the temperature range.</p>	Type	Temperature range	Resolution	Measurement Range	R/S	100 F.S.	0.01	0 to 100	500 F.S.	0.05	0 to 500	2000 F.S.	0.1	R : 0 to 1600 S : 0 to 1760	B	500 F.S.	0.05	400 to 500	2000 F.S.	0.1	500 to 1820	K/E/T/J/N	100 F.S.	0.01	-100 to 100	500 F.S.	0.05	K/E/J/N : -200 to 500	T : -200 to 400	2000 F.S.	0.1	K : -200 to 1370	E : -200 to 800 T : -200 to 400 J : -200 to 1100 N : -200 to 2000	C (W)	100 F.S.	0.01	0 to 100	500 F.S.	0.05	0 to 500	2000 F.S.	0.1	0 to 2000	Pt	100 F.S.	0.01	-100 to 100	500 F.S.	0.05	-200 to 500	2000 F.S.	0.1	Pt100 : -200 to 850	JPt100/Pt1000 : -200 to 500
Type	Temperature range	Resolution	Measurement Range																																																				
R/S	100 F.S.	0.01	0 to 100																																																				
	500 F.S.	0.05	0 to 500																																																				
	2000 F.S.	0.1	R : 0 to 1600 S : 0 to 1760																																																				
B	500 F.S.	0.05	400 to 500																																																				
	2000 F.S.	0.1	500 to 1820																																																				
K/E/T/J/N	100 F.S.	0.01	-100 to 100																																																				
	500 F.S.	0.05	K/E/J/N : -200 to 500																																																				
			T : -200 to 400																																																				
	2000 F.S.	0.1	K : -200 to 1370																																																				
E : -200 to 800 T : -200 to 400 J : -200 to 1100 N : -200 to 2000																																																							
C (W)	100 F.S.	0.01	0 to 100																																																				
	500 F.S.	0.05	0 to 500																																																				
	2000 F.S.	0.1	0 to 2000																																																				
Pt	100 F.S.	0.01	-100 to 100																																																				
	500 F.S.	0.05	-200 to 500																																																				
	2000 F.S.	0.1	Pt100 : -200 to 850																																																				
			JPt100/Pt1000 : -200 to 500																																																				
Reference contact compensation accuracy	Internal/External switching																																																						
A/D converter	Method : method Resolution :16-bit (Effective resolution: About 1/40000 of the +/- range)																																																						
Temperature coefficient	Gain: 0.01% of F.S./°C Zero: 0.02% of F.S./°C * Zero occurs at the sampling intervals of 10, 20, and 50 ms.																																																						
Input resistance	1 MΩ ±5%																																																						
Allowable signal source resistance	Within 300 Ω																																																						
Maximum permissible input voltage	Between +/- terminals : 20 mV to 2 V range (60 Vp-p) 5 V to 100 V range (110 Vp-p) Between input terminal/input terminal : 60 Vp-p Between input terminal/GND : 60 Vp-p																																																						
Withstand voltage	Between input terminal/input terminal : 350 Vp-p 1 minute Between input terminal/GND : 350 Vp-p 1 minute																																																						
Insulation resistance	Between input terminal/GND : 50 MΩ or more (at 500 VDC)																																																						
Common mode rejection ratio	90 dB or more (50/60 Hz; signal source 300 Ω or less)																																																						
Noise	48 dB or more (with +/- terminals shorted)																																																						
Filter	Off, 2, 5, 10, 20, 40 Filter operation is on a moving average basis. The average value of the set sampling count is used. If the sample interval exceeds 30 seconds, the average value of data obtained in a sub-sample (30 seconds) is used.																																																						

* When connected to the GLT400, use it in the ambient temperature range of -20 to 60°C.

Withstand high-voltage high-precision terminal B-565

Item	Description																																																																										
Number of input channels	20ch (200ch available when used with the extension terminal base) * Possible to direct-connect or connect with the extension terminal connection cable (sold separately) between the GLT400 and terminal unit, or between terminal units.																																																																										
Input terminal type	M3 screw type terminals (Rectangular flat washer)																																																																										
Input method	Photo MOS relay scanning system All channels isolated, balanced input * Terminal b to be used to connect the resistance temperature detector is shorted within all channels.																																																																										
Scan speed	10 ms/1 ch maximum																																																																										
Measurement ranges	Voltage: 20, 50, 100, 200, 500 mV; 1, 2, 5, 10, 20, 50, 100 V; 1-5 V F.S. Temperature Thermocouples: K, J, E, T, R, S, B, N, C (WRe5-26) Resistance temperature detector: Pt100, JPt100, Pt1000 (IEC751) Temperature range: 100°C, 500°C, 2000°C (In the case of Fahrenheit: 150°F, 750°F, 3000°F) Humidity: 0 to 100% (voltage 0 V to 1 V scaling conversion) fixed * With B-530 (option)																																																																										
Measurement accuracy (23°C ±5°C) • When 30 minutes or more have elapsed after power was switched on • Sampling 1 s/10 ch • Filter ON (10) • GND connected	Voltage: ± (0.05% of F.S. + 10 μV) Temperature ● Thermocouple <table border="1"> <thead> <tr> <th>Thermocouple</th> <th>Measurement Temperature Range (°C)</th> <th>Measurement Accuracy</th> </tr> </thead> <tbody> <tr> <td rowspan="4">R/S</td> <td>0 ≤ TS ≤ 100</td> <td>±4.5</td> </tr> <tr> <td>100 < TS ≤ 300</td> <td>±3.0</td> </tr> <tr> <td>R : 300 < TS ≤ 1600</td> <td>±2.2</td> </tr> <tr> <td>S : 300 < TS ≤ 1760</td> <td>±2.2</td> </tr> <tr> <td rowspan="2">B</td> <td>400 ≤ TS ≤ 600</td> <td>±3.5</td> </tr> <tr> <td>600 < TS ≤ 1820</td> <td>±2.5</td> </tr> <tr> <td rowspan="2">K</td> <td>-200 ≤ TS ≤ -100</td> <td>±1.5</td> </tr> <tr> <td>-100 < TS ≤ 1370</td> <td>±0.8</td> </tr> <tr> <td rowspan="2">E</td> <td>-200 ≤ TS ≤ -100</td> <td>±1.0</td> </tr> <tr> <td>-100 < TS ≤ 800</td> <td>±0.8</td> </tr> <tr> <td rowspan="2">T</td> <td>-200 ≤ TS ≤ -100</td> <td>±1.5</td> </tr> <tr> <td>-100 < TS ≤ 400</td> <td>±0.6</td> </tr> <tr> <td rowspan="3">J</td> <td>-200 ≤ TS ≤ -100</td> <td>±1.0</td> </tr> <tr> <td>-100 < TS ≤ 100</td> <td>±0.8</td> </tr> <tr> <td>100 < TS ≤ 1100</td> <td>±0.6</td> </tr> <tr> <td rowspan="2">N</td> <td>-200 ≤ TS < 0</td> <td>±2.2</td> </tr> <tr> <td>0 ≤ TS ≤ 1300</td> <td>±1.0</td> </tr> <tr> <td>C (W)</td> <td>0 ≤ TS ≤ 2000</td> <td>±1.8</td> </tr> <tr> <td colspan="2">Reference contact compensation accuracy</td> <td>±0.3</td> </tr> </tbody> </table> <p>* Thermocouple diameters T - K: 0.32 , others: 0.65</p> <p>● Resistance bulb</p> <table border="1"> <thead> <tr> <th>Type</th> <th>Measurement Temperature Range (°C)</th> <th>Applied current</th> <th>Measurement Accuracy</th> </tr> </thead> <tbody> <tr> <td rowspan="3">Pt100</td> <td>-200 ≤ TS ≤ 100</td> <td rowspan="3">1 mA</td> <td>±0.6</td> </tr> <tr> <td>100 < TS ≤ 500</td> <td>±0.8</td> </tr> <tr> <td>500 < TS ≤ 850</td> <td>±1.0</td> </tr> <tr> <td rowspan="2">JPt100</td> <td>-200 ≤ TS ≤ 100</td> <td rowspan="2">1 mA</td> <td>±0.6</td> </tr> <tr> <td>100 < TS ≤ 500</td> <td>±0.8</td> </tr> <tr> <td rowspan="2">Pt1000</td> <td>-200 ≤ TS ≤ 100</td> <td rowspan="2">0.3 mA</td> <td>±0.6</td> </tr> <tr> <td>100 < TS ≤ 500</td> <td>±0.8</td> </tr> </tbody> </table> <p>* 3-wire system</p>	Thermocouple	Measurement Temperature Range (°C)	Measurement Accuracy	R/S	0 ≤ TS ≤ 100	±4.5	100 < TS ≤ 300	±3.0	R : 300 < TS ≤ 1600	±2.2	S : 300 < TS ≤ 1760	±2.2	B	400 ≤ TS ≤ 600	±3.5	600 < TS ≤ 1820	±2.5	K	-200 ≤ TS ≤ -100	±1.5	-100 < TS ≤ 1370	±0.8	E	-200 ≤ TS ≤ -100	±1.0	-100 < TS ≤ 800	±0.8	T	-200 ≤ TS ≤ -100	±1.5	-100 < TS ≤ 400	±0.6	J	-200 ≤ TS ≤ -100	±1.0	-100 < TS ≤ 100	±0.8	100 < TS ≤ 1100	±0.6	N	-200 ≤ TS < 0	±2.2	0 ≤ TS ≤ 1300	±1.0	C (W)	0 ≤ TS ≤ 2000	±1.8	Reference contact compensation accuracy		±0.3	Type	Measurement Temperature Range (°C)	Applied current	Measurement Accuracy	Pt100	-200 ≤ TS ≤ 100	1 mA	±0.6	100 < TS ≤ 500	±0.8	500 < TS ≤ 850	±1.0	JPt100	-200 ≤ TS ≤ 100	1 mA	±0.6	100 < TS ≤ 500	±0.8	Pt1000	-200 ≤ TS ≤ 100	0.3 mA	±0.6	100 < TS ≤ 500	±0.8
Thermocouple	Measurement Temperature Range (°C)	Measurement Accuracy																																																																									
R/S	0 ≤ TS ≤ 100	±4.5																																																																									
	100 < TS ≤ 300	±3.0																																																																									
	R : 300 < TS ≤ 1600	±2.2																																																																									
	S : 300 < TS ≤ 1760	±2.2																																																																									
B	400 ≤ TS ≤ 600	±3.5																																																																									
	600 < TS ≤ 1820	±2.5																																																																									
K	-200 ≤ TS ≤ -100	±1.5																																																																									
	-100 < TS ≤ 1370	±0.8																																																																									
E	-200 ≤ TS ≤ -100	±1.0																																																																									
	-100 < TS ≤ 800	±0.8																																																																									
T	-200 ≤ TS ≤ -100	±1.5																																																																									
	-100 < TS ≤ 400	±0.6																																																																									
J	-200 ≤ TS ≤ -100	±1.0																																																																									
	-100 < TS ≤ 100	±0.8																																																																									
	100 < TS ≤ 1100	±0.6																																																																									
N	-200 ≤ TS < 0	±2.2																																																																									
	0 ≤ TS ≤ 1300	±1.0																																																																									
C (W)	0 ≤ TS ≤ 2000	±1.8																																																																									
Reference contact compensation accuracy		±0.3																																																																									
Type	Measurement Temperature Range (°C)	Applied current	Measurement Accuracy																																																																								
Pt100	-200 ≤ TS ≤ 100	1 mA	±0.6																																																																								
	100 < TS ≤ 500		±0.8																																																																								
	500 < TS ≤ 850		±1.0																																																																								
JPt100	-200 ≤ TS ≤ 100	1 mA	±0.6																																																																								
	100 < TS ≤ 500		±0.8																																																																								
Pt1000	-200 ≤ TS ≤ 100	0.3 mA	±0.6																																																																								
	100 < TS ≤ 500		±0.8																																																																								

Item	Description																																																						
	<p>● Temperature range</p> <table border="1"> <thead> <tr> <th>Type</th> <th>Temperature range</th> <th>Resolution</th> <th>Measurement Range</th> </tr> </thead> <tbody> <tr> <td rowspan="3">R/S</td> <td>100 F.S.</td> <td>0.01</td> <td>0 to 100</td> </tr> <tr> <td>500 F.S.</td> <td>0.05</td> <td>0 to 500</td> </tr> <tr> <td>2000 F.S.</td> <td>0.1</td> <td>R : 0 to 1600 S : 0 to 1760</td> </tr> <tr> <td rowspan="2">B</td> <td>500 F.S.</td> <td>0.05</td> <td>400 to 500</td> </tr> <tr> <td>2000 F.S.</td> <td>0.1</td> <td>500 to 1820</td> </tr> <tr> <td rowspan="4">K/E/T/J/N</td> <td>100 F.S.</td> <td>0.01</td> <td>-100 to 100</td> </tr> <tr> <td>500 F.S.</td> <td>0.05</td> <td>K/E/J/N : -200 to 500 T : -200 to 400</td> </tr> <tr> <td rowspan="4">2000 F.S.</td> <td rowspan="4">0.1</td> <td>K : -200 to 1370</td> </tr> <tr> <td>E : -200 to 800</td> </tr> <tr> <td>T : -200 to 400</td> </tr> <tr> <td>J : -200 to 1100 N : -200 to 2000</td> </tr> <tr> <td rowspan="3">C (W)</td> <td>100 F.S.</td> <td>0.01</td> <td>0 to 100</td> </tr> <tr> <td>500 F.S.</td> <td>0.05</td> <td>0 to 500</td> </tr> <tr> <td>2000 F.S.</td> <td>0.1</td> <td>0 to 2000</td> </tr> <tr> <td rowspan="3">Pt</td> <td>100 F.S.</td> <td>0.01</td> <td>-100 to 100</td> </tr> <tr> <td>500 F.S.</td> <td>0.05</td> <td>-200 to 500</td> </tr> <tr> <td>2000 F.S.</td> <td>0.1</td> <td>Pt100 : -200 to 850 JPt100/Pt1000 : -200 to 500</td> </tr> </tbody> </table> <p>* Measurement accuracy does not change due to the temperature range.</p>	Type	Temperature range	Resolution	Measurement Range	R/S	100 F.S.	0.01	0 to 100	500 F.S.	0.05	0 to 500	2000 F.S.	0.1	R : 0 to 1600 S : 0 to 1760	B	500 F.S.	0.05	400 to 500	2000 F.S.	0.1	500 to 1820	K/E/T/J/N	100 F.S.	0.01	-100 to 100	500 F.S.	0.05	K/E/J/N : -200 to 500 T : -200 to 400	2000 F.S.	0.1	K : -200 to 1370	E : -200 to 800	T : -200 to 400	J : -200 to 1100 N : -200 to 2000	C (W)	100 F.S.	0.01	0 to 100	500 F.S.	0.05	0 to 500	2000 F.S.	0.1	0 to 2000	Pt	100 F.S.	0.01	-100 to 100	500 F.S.	0.05	-200 to 500	2000 F.S.	0.1	Pt100 : -200 to 850 JPt100/Pt1000 : -200 to 500
Type	Temperature range	Resolution	Measurement Range																																																				
R/S	100 F.S.	0.01	0 to 100																																																				
	500 F.S.	0.05	0 to 500																																																				
	2000 F.S.	0.1	R : 0 to 1600 S : 0 to 1760																																																				
B	500 F.S.	0.05	400 to 500																																																				
	2000 F.S.	0.1	500 to 1820																																																				
K/E/T/J/N	100 F.S.	0.01	-100 to 100																																																				
	500 F.S.	0.05	K/E/J/N : -200 to 500 T : -200 to 400																																																				
	2000 F.S.	0.1	K : -200 to 1370																																																				
			E : -200 to 800																																																				
T : -200 to 400																																																							
J : -200 to 1100 N : -200 to 2000																																																							
C (W)	100 F.S.	0.01	0 to 100																																																				
	500 F.S.	0.05	0 to 500																																																				
	2000 F.S.	0.1	0 to 2000																																																				
Pt	100 F.S.	0.01	-100 to 100																																																				
	500 F.S.	0.05	-200 to 500																																																				
	2000 F.S.	0.1	Pt100 : -200 to 850 JPt100/Pt1000 : -200 to 500																																																				
Reference contact compensation accuracy	Internal/External switching																																																						
A/D converter	Method: method Resolution: 16-bit (Effective resolution: About 1/40000 of the +/- range)																																																						
Temperature coefficient	Gain: 0.01% of F.S./°C Zero: 0.02% of F.S./°C * Zero occurs at the sampling intervals of 10, 20, and 50 ms.																																																						
Input resistance	1MΩ ±5%																																																						
Allowable signal source resistance	Within 100Ω																																																						
Maximum permissible input voltage	Between +/- terminals : 20 mV to 2 V (60 Vp-p) 5 V to 100 V (110 0Vp-p) Between input terminal/input terminal : 600 Vp-p Between input terminal/GND : 300 Vp-p																																																						
Withstand voltage	Between input terminal/input terminal : 600 Vp-p Between input terminal/GND : 2300 VACrms 1 minute																																																						
Insulation resistance	Between input terminal/GND : 50MΩ or more (at 500 VDC)																																																						
Common mode rejection ratio	90 dB or more (50/60 Hz; signal source 300Ω or less)																																																						
Noise	48 dB or more (with +/- terminals shorted)																																																						
Filter	Off, 2, 5, 10, 20, 40 Filter operation is on a moving average basis. The average value of the set sampling count is used. If the sample interval exceeds 30 seconds, the average value of data obtained in a sub-sample (30 seconds) is used.																																																						

* Even when connected to the GLT400, the ambient temperature is the range of 0 to 45°C.

5.2 Function Specifications

Function Specifications

Item	Description	
Sampling interval	10 ms/1 ch maximum (GBD/CSV-formatted) 10, 20, 50, 100, 125, 200, 250, 500 ms; 1, 2, 5, 10, 20, 30 sec.; 1, 2, 5, 10, 20, 30 min, 1 hour; External * "External" can be selected only when the GLT400 is set to STAND-ALONE. * Measurement CH 125 ms or less can be set depending on the input setting.	
EU (scaling function)	<ul style="list-style-type: none"> • 4 points can be set for each channel • Temperature range scaling function is available 	
Functions during capture	Replacement of the SD CARD	
Data save function	Capture destination: Internal memory or SD CARD Captured data: Settings, Screen data, measured data	
Capture function	Function: OFF, Ring capturing, Relay capturing	
	Ring capturing	Number of capturing points: 1000 to 2000000 * When ring capture is ON, the memory space that can be used for capture is one third of the free space or less.
	Relay capturing	The captured data is continuously captured by files separated in the set relay unit without losing data.
Calculation between CHs	Calculation type: Four arithmetic operations (+, -, ×, ÷) Target input: Analog CH1 to CH200	
Annotation input function	Function: A comment can be entered for each channel Input table characters: Alphanumerics Number of characters: 31	

Trigger / Alarm Functions

Item	Description
Repeat Trigger	Off, On
Trigger types	Start: Data capture starts when a trigger is generated. Stop: Data capture stops when a trigger is generated.
Trigger conditions	Start: Off, level value, alarm, external input, specified time, specified day of the week, certain time Stop: Off, level value, alarm, external input, specified time, specified day of the week, certain time
Alarm judgment modes	Combination: Analog, Logic or "AND" / "OR" of pulse Analog judgment: H (↑), L (↓), Window In, Window Out Logic judgment: Pattern Pulse judgment: H (↑), L (↓), Window In, Window Out

External Input/Output Functions

Item	Description
Input/output types	<ul style="list-style-type: none"> • Trigger input (1 ch) or External sampling input (1 ch) • Logic input (4 ch) or Pulse input (4 ch) (Only when the GLT400 is set to STAND-ALONE) • Alarm output (4 ch) (Only 1 ch when the GLT400 is set to REMOTE) * Switch between Logic and Pulse. * Switch between Trigger and External sampling. * The Input/output cable for GL B-513 (option) is required to use the external output function.
Input specifications	Input voltage range : 0 to +30 V (single-ended ground input) Input signal: No-voltage contact (a-contact, b-contact, NO, NC), Open collector, Voltage input Input threshold voltage: Approx. +2.5 V Hysteresis: Approx. 0.5 V (+2.5 to +3 V) * Refer to "2.11 Logic Alarm Cable Connection and Functions" for details on the input circuit.
Alarm output specifications	Output format: Open collector output (5 V, pull-up resistance 10 k Ω) <Maximum ratings of output transistor> <ul style="list-style-type: none"> • Collector-GND voltage : 50 V • Collector current: 2 A • Collector dissipation: 0.3 W * Refer to "2.11 Logic Alarm Cable Connection and Functions" for details on the output circuit. Output conditions: Level judgment, window judgment, logic pattern judgment, pulse judgment.
Pulse input (Only when the GLT400 is set to STAND-ALONE)	Revolutions mode (engines, etc.) Function: This mode counts the number of pulses per sampling interval, and then converts them by multiplying the scaling factor to the RPM. Settable the number of pulses per revolution during revolution Spans: 50, 500, 5000, 50 k, 500 k, 5 M, 50 M, 500 M RPM/F.S.
	Counts mode (electric meters, etc.) Function: Displays a count of the number of pulses for each sampling interval from the start of measurement. Spans: 50, 500, 5000, 50 k, 500 k, 5 M, 50 M, 500 M C/F.S.
	Inst. mode Function: Counts the number of pulses for each sampling interval. Resets the count value after each sampling interval. Spans: 50, 500, 5000, 50 k, 500 k, 5 M, 50 M, 500 M C/F.S.
	Maximum number of pulse inputs Maximum input frequency: 50 kHz Maximum number of count: 50 kC/sampling (16-bit counter)

5.3 List of Error Codes

If an error occurs in the GLT400, the POWER LED is lit in red and a buzzer sounds. To check the error description, connect the GLT400 Setting App. The error codes are listed below.

Operation and setting errors

Code number	Error	Description
101	Ring capturing condition error	The number of ring capturing points exceeds the capacity of the capturing destination.
102	Backup condition error	When saving in CSV format, specify a sampling interval slower than 100 ms.
103	- Ditto -	- Ditto -
105	Invalid trigger condition (Start trigger)	There are no valid channels for the trigger start condition. Change the trigger condition.
106	Invalid trigger condition (Stop trigger)	There are no valid channels for the trigger stop condition. Change the trigger condition.
107	Disk full	The disk capacity is full.
108	Disk error	Disk input and output error has occurred.
109	Backup condition error	The data capturing destination and backup destination cannot be specified on the same media.
111	Backup condition error	The backup destination folder cannot be created.
112	System error	Memory capacity is insufficient.
113	Backup condition error	The relay capturing setting is On. Backup is not performed.
114	Backup condition error	Backup is not performed when external sampling is enabled.
115	Backup condition error	The remaining capacity of the capturing media is insufficient. If you want to delete the captured files when the backup is successful, you need at least twice the free space as it was when the relay was set.
117	Invalid AMP configuration	Because the current AMP configuration and the AMP configuration in the setting file are different, the AMP is not set.
118	Setting file error	The contents of the setting file are incorrect.
119	Capturing error	During capturing, the capturing start command was received again.
120	Disk error	Capturing destination error
122	Backup condition error	The ring capturing setting is On. Backup is not performed.
123	Disk error	Disk remaining capacity is not enough.
125	Easy Connection (WPS) failure	Wireless LAN Easy Connection (WPS) failed.
127	SD CARD write protect	The SD CARD is write-protected.
128	Capturing condition error	Capturing cannot be started in REMOTE mode.
130	SD CARD replacement error	The SD CARD cannot be replaced.
131	Disk error	There is no SD CARD for the capturing destination.
132	E-mail error	E-mail send failed.
133	Backup operation error	Backup failed.
134	Invalid trigger condition (Start trigger)	There is no valid start trigger condition.
135	Invalid trigger condition (Stop trigger)	There is no valid stop trigger condition.

Disk error

If a disk error has occurred, try the following:

Turn on the power of the GLT400 again

Disk initialization

Change to another disk (for SD CARD)

No.	Description
1001	This is an error that cannot be processed.
1002	The target file or directory does not exist.
1003	The hardware may have failed. Please contact us.
1005	The internal memory or SD CARD may have failed.
1008	There is a problem in the internal memory or the SD CARD.
1009	Please contact us.
1012	The memory capacity within the system is insufficient.
1013	It is write-protected. Check the write-protect switch of the SD CARD.

No.	Description
1016	Attachment upper limit error
1017	The file/folder already exists.
1021	The operation target is not a file. You tried to perform a file operation on a folder.
1022	Illegal path or file name.
1023	There are too many open files.
1024	There are too many open files.
1027	The file size limit has been exceeded.
1028	There is no space for media.
1046	Lock error
1088	An unsupported disk format is being used.
1090	The target folder is not empty.
1100	Please contact us.
1101	Please contact us.
1102	Please contact us.

Warning code

When a warning occurs, the POWER LED is lit in red and a buzzer sounds. To check the warning information, connect the GLT400 Setting App. The warnings are listed below.

No.	Warning	Description
116	The SD CARD is write-protected.	The write-protected SD CARD is inserted. If the capturing destination is other than the SD CARD, no problem occurs.
124	The disk capacity is low.	The warning is output when the capturing destination capacity is low.
129	Warning for connection terminal	Terminal of other models is installed. Please note that the accuracy of temperature measurement may not meet the specifications.

5.4 Accessories / Optional Accessories

Control Software GL-Connection (in STAND-ALONE mode only)

Item	Description
Supported OS	Windows 11 / Windows 10 / Windows 8.1 * Meet system requirements of the OS.
Function	Main unit control, realtime data capture, data conversion
Number of groups	4 groups MAX
Number of CHs per 1 group	Up to number of connected units
Maximum number of channels	1000 ch maximum
Settings	AMP settings, capture settings, trigger/alarm settings, others
Captured data	Realtime data (CSV, GBD Binary) Data in Internal memory or SD CARD (CSV, GBD binary)
Display	Analog waveforms, logic waveforms, pulse waveforms, digital values
Display modes	Y-T View, Digital View, X-Y View, FFT View
File conversion	Between cursors, All data
Monitor functions	Alarm monitor enables sending of e-mail to the specified address
Statistic/History	The e-mail is sent to the specified address when the alarm monitor is performed.
E-mail function	Alarm monitor enables sending of e-mail to the specified address

Accessories

Item	Remarks	Quantity
Quick Start Guide	GLT400-UM-85x	1
AC cable/AC adapter	100 to 240 VAC, 50/60 Hz	1
Spacer	Large: 1, Small: 2 (Used when the terminal base is installed.)	1 set
TO ENSURE SAFE AND CORRECT USE	SAFETY PAMPHLET	1

Wireless LAN Unit B-568 (Option)

Item	Description
Communication system	Wireless LAN
Installation location	Insert into the SD CARD slot * When the wireless unit is inserted, an SD CARD cannot be inserted into the SD CARD slot.
Wireless LAN standard	IEEE802.11b/g/n
Function	Communication range: Approx. 40 m * Communication range depends on the obstacles and the surrounding environmental conditions. Control from PC, data transfer to PC (Connected as a remote unit of GL840 in REMOTE mode) WPS : Push button method / PIN method Encryption function : WEP64, WEP128, WPA-PSK/WPA 2-PSK, TKIP/AES

Humidity Sensor B-530 (Option)

Item	Description	
Allowable temperature range	-25 to +80°C	
Allowable humidity range	0 to 100% RH	
Relative humidity measurement accuracy	±3% RH (5 to 98% RH at 25°C)	
Method	Capacitance method	
Relative humidity measurement accuracy (5 to 98%)	Measurement environment	Measurement accuracy
	0 to 10	±5% RH
	10 to 20	±4% RH
	20 to 30	±3% RH
	30 to 40	±4% RH
	40 to 50	±5% RH
	50 to 60	±6% RH
	60 to 70	±7% RH
	70 to 80	±8% RH
* Measurement accuracy at 60°C or more is a reference value.		
Response time	15 sec. (90% response when membrane filter is installed)	
Sensor output	0 to 1 VDC	
External dimensions	14 × 80 mm (excluding cable)	
Cable length	3 m	
Sensor power source	+5 to +16 VDC	
Power consumption	approx. 4 mA	

List of Options

Item	Model	Description
Input/output cable for GL series	B-513	2 m, Bare tips
DC drive cable	B-514	2 m, Bare tips
Humidity sensor*1	B-530	3 m, with a dedicated power connector
Input terminal (Multi-inputs)	B-564	20ch Standard terminal
Input terminal (Withstand voltage)	B-565	20ch Withstand high-voltage high-precision terminal
Screwless input terminal	B-564SL	20ch Screwless terminal
Base unit for input terminal	B-566	Expansion terminal base unit, Connecting plate, Screws
Connection cable for extension terminal	B-567-05	Connection cable (50 cm)
	B-567-20	Connection cable (2 m)
Wireless LAN unit	B-568	Wireless LAN
Bracket for DIN rail	B-540	Built to order
Shunt resistance	B-551-10	Built to order 250Ω (± 0.1%), rated power 1W, maximum operating voltage 15.8V
Input terminal cover	B-588	Protective cover

*1: Allowable temperature range: -25 to +80°C

5.5 External Dimensions

GLT400 (with terminal)

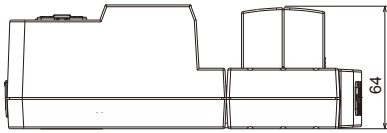

Standard terminal: B-564

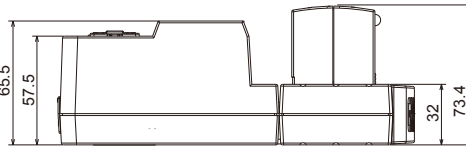

Withstand high-voltage high-precision terminal: B-565

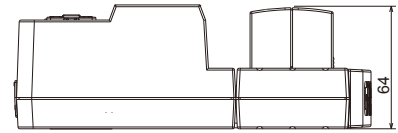

Screwless terminal: B-564SL

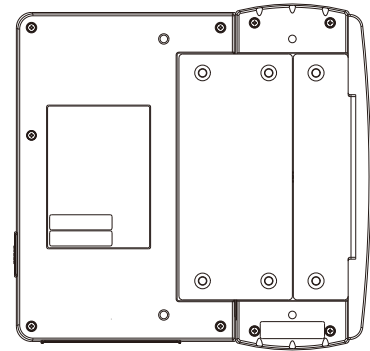
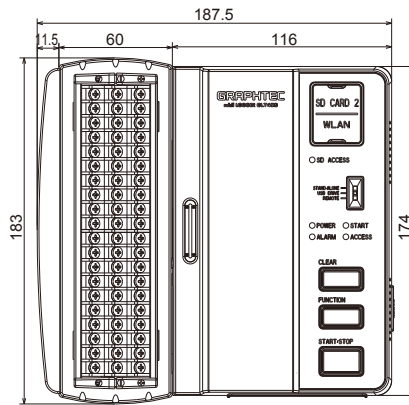
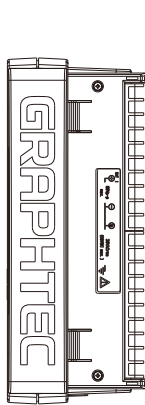

Unit: mm
Dimension precision: Error ± 0.5 mm

Terminals

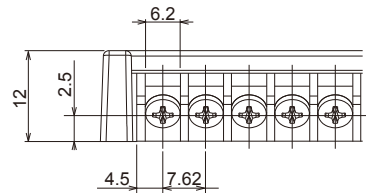

Unit: mm
Dimension precision: Error ± 0.5 mm

INDEX

A	
ACCESS	3-7
Accessories	5-12
AC line filter	4-22
AC Line Frequency	4-45
AC Power Supply	2-18
Add checksum to file	4-46
A/D resolution	2-22, 2-23
ALARM	3-7
Alarm hold	4-29
Alarm level settings	4-29
Alarm Output	2-24
Amplifier settings	4-10
Analog settings	4-11
B	
Backup setting	4-26
Burnout	4-45
Buzzer	3-8, 4-44
C	
Captured data file name	4-22
Checking the Accessories	2-2
CLEAR	3-5
Connecting to a PC	2-31
Connection to the wireless LAN	2-33
Connection Using a USB Cable	2-31
Control Software	5-12
D	
Data	3-24
Date/Time	4-46
DC Power Supply	2-19
Dead zones	4-32
Demo Waveform Mode	4-47
Description of Screen	4-5
DNS Address	4-37
E	
Easy Connection	4-35
Edge operations	4-31
Engineering unit setting	4-18
Error log	4-8
EU	4-14, 4-18
External Dimensions	5-14
External Input/Output Functions	5-9
External sampling	4-21
External Sampling Input	2-24
F	
File handling	4-7
File Operations Screen	4-48
Filter	2-22, 2-23, 4-13, 4-17
FUNCTION	3-5
Function Specifications	5-8
H	
How to insert the SD CARD	2-27
How to insert the wireless LAN unit	2-29
How to remove the SD CARD	2-28
Humidity Sensor B-530 (Option)	5-13
I	
Information	4-46
Initializes network settings	4-46
Initializes operation settings	4-46
Input	4-11, 4-17
Input/output cable	2-24
Interface settings	4-33
IP Address Auto Acquisition	4-37
K	
Keep Alive	4-38
Key click sound	3-8
Key Operation	3-4
L	
LAN Connection	2-32
LAN connector	3-7
Language setting	4-46
Level operations	4-31
List of Error Codes	5-10
List of Options	5-13
Logic/Pulse	4-17
Logic/Pulse Input	2-24
M	
Memory devices	5-3
Mode Switch Operation	3-2
Monitor	4-7
Monitor Screen	4-49
N	
Nomenclature and Functions	2-3
NTP Server	4-43
Number of pulses per revolution	4-19
O	
Operating environment	4-2
Operating Environment	1-3
Operation of LED	3-6
Optional Accessories	5-12

Option settings	4-8
OTHER settin	4-44
Overview of GLT400 SETTING APP	4-2

P

PASV mode	4-39
PC I/F	5-3
Port Number	4-37
POWER	3-6
Power On Start	4-44
Power supply function	5-3
Pulse Slope	4-17

R

Range	4-11
Relay Capture Function	4-25
REMOTE	3-2
REMOTE mode	4-6
Removing the wireless LAN unit	2-30
Repeat capturing	4-29
Replacement of SD CARD	3-8
Restart the GLT400	4-46
Ring Capture Function	4-24
Ring/Relay capture settings	4-24
Room temperature compensation	4-45

S

Safety Precautions	ii
Sampling interval	4-21
Save / Load Current Settings Screen	4-50
Saving and loading settings	4-8
Scaling settings	4-14
SD ACCESS	3-7
SD CARD	2-27
Send burnout alarm	4-29
Sensor	4-11
Settings screen	4-6, 4-9
Software installation	4-3
STAND-ALONE	3-2
STAND-ALONE mode	4-6
Standard Specifications	5-2
START	3-6
Start side source setting	4-28
START/STOP	3-4
Start/stop capturing	3-8
Stop side source setting	4-28

T

TCP-IP settings	4-37
Temp. Unit	4-45
To Ensure Safe and Correct Use	i
Trigger / Alarm Functions	5-8
Trigger Input	2-24
Trigger level settings	4-30
TRIG settings	4-27

U

USB DRIVE	3-2
USB ID	4-35
USB Power Delivery	5-3
USB settings	4-35

W

Warming-up Before Use	1-3
WEB Server Function	3-22
When an error occurs	3-8
Wireless LAN Easy Connection	3-9
Wireless LAN settings	4-35
Wireless LAN Unit B-568 (Option)	5-12
Wireless Unit	2-29
WPS	3-9

Specifications are subject to change without notice.

GLT400 User's Manual
GLT400-UM-151
December 10, 2021 2nd edition

GRAPHTEC CORPORATION

GRAPHTEC